

## INSTALLATION, OPERATION, & MAINTENANCE INSTRUCTIONS FOR SINGLE TOWER COMPRESSED AIR DRYER MODELS D-12 through D-36

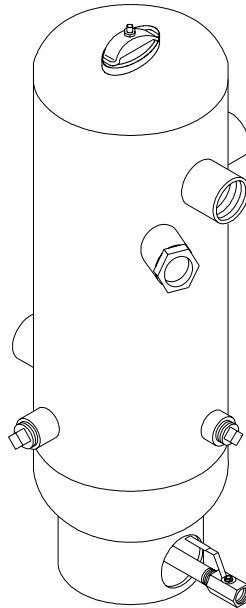

### WARNING

DO NOT REMOVE, REPAIR, OR REPLACE ANY ITEM ON THE DRYER WHILE IT IS UNDER PRESSURE. DEPRESSURIZE THE DRYER COMPLETELY BEFORE STARTING INSTALLATION AND/OR MAINTENANCE PROCEDURES. SERIOUS PERSONAL INJURY MAY RESULT IF THESE SAFETY RULES ARE NOT FOLLOWED.

DO NOT OPERATE THIS PRESSURE VESSEL ABOVE MAXIMUM WORKING PRESSURE (MWP) AT MAXIMUM OPERATING TEMPERATURE (°F) AS SHOWN ON THE ASME DATA PLATE.

THIS ASME CODE VESSEL MUST BE PROTECTED BY A PRESSURE RELIEF VALVE. Refer to OSHA 1910.169 Par. b, Sub. Par (3) and ASME Boiler and Pressure Vessel Code, Section VIII, Division 1, UG-125 through UG-136. Also check government regulations, i.e., state and local codes.

DO NOT WELD, GRIND, OR SAND VESSEL, OR IT WILL NOT BE SAFE TO OPERATE. (Note: Any alteration to the vessel will void the ASME Code Certification and the warranty.)

ANY DAMAGE TO THE VESSEL CAN MAKE IT UNSAFE. INSPECT OUTSIDE AND INSIDE OF VESSELS REGULARLY FOR BULGES, CORROSION, DENTS, GOUGES, LEAKS OR SIGNS OF FIRE. IF DAMAGED, TAKE OUT OF SERVICE IMMEDIATELY AND NOTIFY YOUR CERTIFYING AUTHORITY.

USE THE PROPER SAFETY RULES FOR THE GAS BEING PROCESSED.

DO NOT REMOVE THE HATCH COVER UNTIL ALL AIR PRESSURE IS OUT OF THE VESSEL. PUSH ON THE HATCH COVER BY HAND TO FIND OUT IF THE VESSEL PRESSURE IS REDUCED TO ZERO.

DO NOT TRY TO TIGHTEN THE HATCH COVER IF YOU HEAR OR FEEL A LEAK. IMMEDIATELY SHUT OFF THE AIR OR GAS SUPPLY TO THE VESSEL AND REDUCE THE DRYER PRESSURE TO ZERO.

ALWAYS INSTALL A NEW GASKET EVERY TIME THE HATCH COVER IS REMOVED, OR AT LEAST ONCE PER YEAR. REPLACE THE HATCH COVER EVERY FIVE YEARS REGARDLESS OF CONDITION. USE VAN AIR AUTHORIZED PARTS ONLY.

DO NOT USE POWER TOOLS OR CHEATER BARS TO TIGHTEN THE NUT ON THE COVER. TOO MUCH FORCE CAN DISTORT THE COVER AND/OR THE GASKET. IF DAMAGED BY OVERTIGHTENING, THE COVER CAN BLOW OUT AND CAUSE SERIOUS INJURY. (Note: Tighten the nut until it is snug only. When pressure is in the vessel, the seal will be complete.)

INSPECT THE COVER AND SEALING SURFACE EVERY TIME THE COVER IS REMOVED, OR AT LEAST ONCE PER YEAR, FOR DAMAGE SUCH AS CORROSION, CRACKS, OR DISTORTION. IF THERE IS ANY DAMAGE, INSTALL A NEW COVER AND GASKET. USE VAN AIR AUTHORIZED PARTS ONLY.

## 1.0 PURPOSE OF OPERATION

The purpose of installing a Van Air single tower dryer in a compressed air system is to remove the water vapor (humidity) which has been drawn into the system at the compressor intake. The Van Air process dries the air as it flows through the vessel, which is filled with a special drying agent. The dryer operates automatically. There are no moving parts and no external source of power is required. If an automatic drain is installed, a power source is required only to operate the valve.

The wet air enters the centrally located inlet which channels the flow into the lower portion of the dryer. Liquid water and solid particles are separated by gravity and fall to the bottom of the vessel.

The process air moves upward through the bed of desiccant tablets which attract and absorb the moisture from the air before it flows through the dryer outlet. The tablets dissolve gradually as they absorb the moisture.

The tablets create a structured bed that does not crush under its own weight. In the bed of an operating dryer, the lower tablets are consumed first.

The tablets above the sight windows are virtually unused and serve as a reserve supply. When the reserve supply is depleted, the dryer must be refilled to maintain performance.

The solution, which consists of dissolved desiccant and water, falls into the claim area at the bottom of the vessel. The dryer must be drained at least once a shift to remove the accumulated solution. The drain solution may contain lubricants and must be disposed of properly.

FIGURE 1 DRYER DETAILS

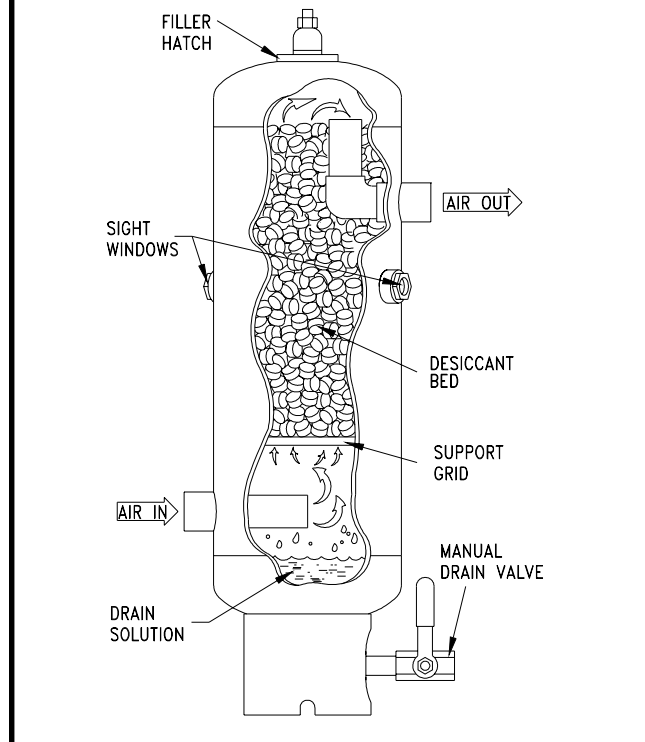

## SECTION 2

## INSTALLATION

### 2.1 LOCATION

The ability of a dryer to provide dry compressed air depends on the correct location of the unit. Inlet air temperature and pressure are the keys to selecting the proper location.

**IMPORTANT**  
**ALWAYS PROCESS AIR THROUGH THE DRYER AT THE LOWEST POSSIBLE TEMPERATURE AND THE HIGHEST PRACTICAL PRESSURE.**

#### 2.1-A INLET AIR TEMPERATURE

The dew point of the outlet air is directly related to the inlet air temperature and the type of desiccant being used. The lower the inlet temperature, the lower the dew point of the outlet air. Determine the lowest ambient temperature where the compressed air is used or where the lines are located. If you are using DRY-O-LITE or 10BF desiccants, do not exceed 100°F inlet air temperature. If you are using SP desiccant, do not exceed 80°F inlet air temperature.

#### 2.1-B AFTERCOOLING

Air discharged by the compressor is extremely hot (from 150°F to 350°F). An aftercooler, finned tubing or extended run of piping will usually be necessary to reduce the inlet air temperature to the dryer.

#### 2.1-C OUTDOOR AIR USAGE

If some or all of the air supplied by the Van Air single tower dryer will be used outdoors, install the dryer outdoors in the coolest possible area. Make sure that the dryer is not exposed to ambient temperatures below the minimum design temperature stamped on the vessel data tag. When the dryer will be exposed to the direct rays of the sun, install a sun shield to protect it (i.e. a roof).

#### 2.1-D INDOOR AIR USAGE

If all of the air from the dryer will be used indoors where

temperatures remain within a fixed range, locate the dryer in the coolest indoor area. When air equipment or piping is located in an air conditioned area, install the dryer in the coolest area--usually the air conditioned area.

#### 2.1-E AIR RECEIVER

In relation to the air receiver, the Van Air single tower dryer should be located where it will be provided with the coolest inlet temperature. If the receiver is located in an area where the ambient temperature is lower than the outlet air from the aftercooler, locate the dryer downstream of the receiver to allow additional cooling of the air before it enters the dryer. (Exception: In systems where usage creates sudden demands on the air supply, locate dryer before the receiver to minimize air surges through the dryer.) If the ambient temperature around the receiver is higher than the outlet air temperature from the aftercooler, locate the dryer between the aftercooler and the receiver.

#### 2.1-F SPECIAL EQUIPMENT INSTALLATION

If the Van Air dryer is being installed on a branch line to protect a specific piece of air-operated equipment, locate the dryer on the high pressure side of any pressure regulators.

#### 2.1-G OPERATING PRESSURE

More air can be processed through the dryer at higher pressures. Locate the dryer at the highest practical pressure, but do not exceed the maximum rated working pressure of the dryer. Refer to the Maximum Capacities chart on Page 3 for the maximum working pressure for your dryer.

## 2.2 PIPING AND ANCILLARY EQUIPMENT

Locate the dryer in the proper location as explained in the previous section.

If the dryer is being installed in an existing piping system, make sure that the pipe is free of scale and rust.

FIGURE 2 MAXIMUM CAPACITIES -SCFM (Nm<sup>3</sup>/hr)

MODEL NO.	MAXIMUM WORKING PRESSURE	5 PSIG 0.3 Bar	10 PSIG 0.7 Bar	20 PSIG 1.4 Bar	40 PSIG 2.8 Bar	60 PSIG 4.1 Bar	80 PSIG 5.5 Bar	100 PSIG 6.9 Bar	125 PSIG 8.6 Bar	150 PSIG 10.3 Bar	175 PSIG 12.1 Bar	200 PSIG 13.8 Bar	250 PSIG 17.2 Bar
D-12	250 PSIG	17 29	22 37	30 51	48 81	65 111	83 140	100 170	122 207	144 244	165 281	187 318	231 392
D-16	250 PSIG	27 45	33 57	47 80	74 126	101 172	128 217	155 263	189 321	223 378	256 436	290 493	358 608
D-20	200 PSIG	43 73	54 91	76 128	119 203	163 277	206 351	250 425	304 517	359 610	414 703	468 795	-- --
D-24	200 PSIG	64 109	81 137	113 193	179 304	244 415	310 526	375 637	457 776	538 915	620 1054	702 1193	-- --
D-30	200 PSIG	107 182	135 229	189 321	298 506	407 692	516 877	625 1062	761 1293	897 1525	1034 1757	1170 1988	-- --
D-36	175 PSIG	146 248	183 311	257 437	405 689	554 941	702 1192	850 1444	1035 1759	1221 2074	1406 2390	-- --	-- --

FIGURE 3 RECOMMENDED INSTALLATION DRAWING

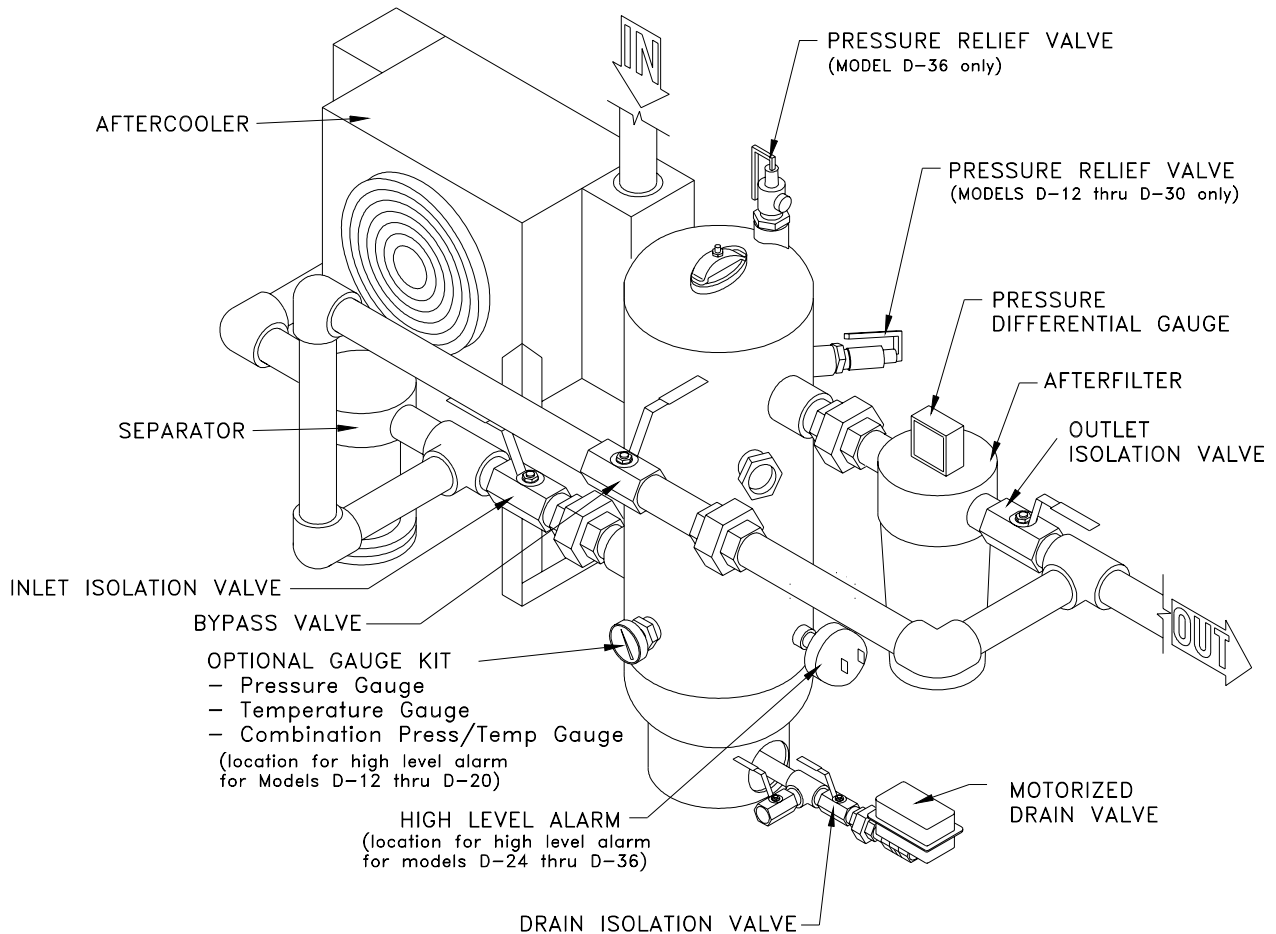

NOTE:  
 ITEMS CALLED OUT IN THIS DRAWING  
 ARE NOT SUPPLIED WITH THE DRYER.  
 REFERENCE FIGURES 1 & 4 FOR ITEMS  
 INCLUDED WITH DRYER.

FIGURE 4 DRYER DIMENSIONAL DETAILS

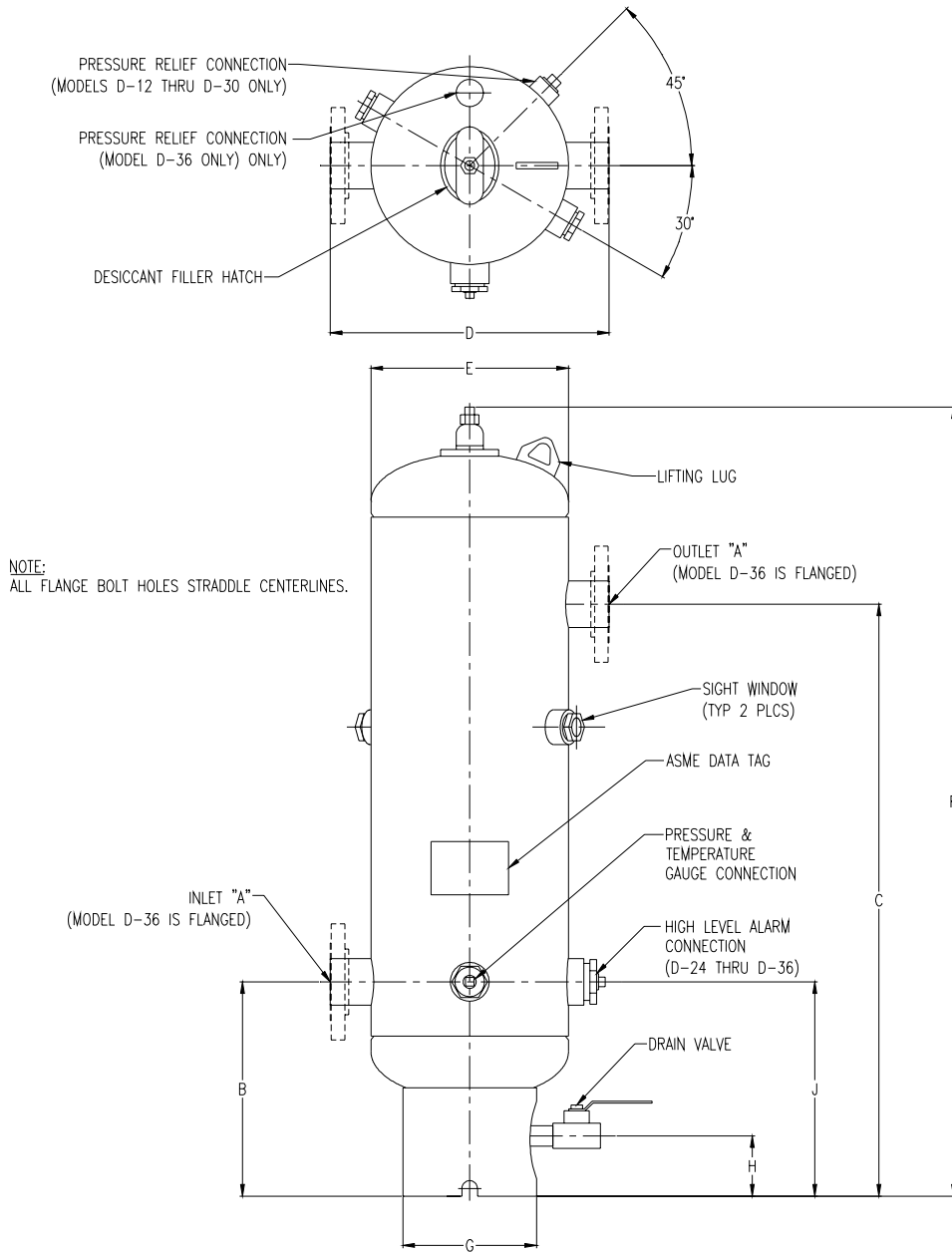

MODEL NO.	APPROX WEIGHT w/o Desiccant	A	B	C	D	E	F	G	H	J	
D-12	130 LBS	2" NPT	13-7/8" 352.4mm	38-1/4" 971.6mm	18" 457.2mm	12-3/4" 323.9mm	51" 1295mm	8-5/8" 219.1mm	3-7/8" 98.4mm	NA NA	
D-16	145 LBS	2" NPT	15-1/2" 393.7mm	41-3/4" 1060.5mm	19-1/2" 495.3mm	16" 406.4mm	54-5/8" 1387.5mm	12-3/4" 323.9mm	3-1/2" 88.9mm	NA NA	
D-20	210 LBS	2" NPT	15-3/4" 400.1mm	42-5/8" 1082.7mm	23-1/2" 596.9mm	20" 508mm	55-7/8" 1419.2mm	16" 406.4mm	3-3/8" 85.7mm	NA NA	
D-24	285 LBS	2" NPT	17" 431.8mm	44" 1117.6mm	26" 660.4mm	24" 609.6mm	58-3/4" 1492.3mm	16" 406.4mm	3-3/4" 95.3mm	17" 431.8mm	
D-30	640 LBS	3" NPT	21-7/8" 555.6mm	44-7/8" 1139.8mm	32" 812.8mm	30" 762mm	63-1/2" 1612.9mm	24" 609.6mm	4-3/8" 111.1mm	19-5/8" 498.5mm	
D-36	780 LBS	3" 150# FLANGE	24-5/8" 65.5mm	48-5/8" 1235.1mm	44-5/8" 1133.5mm	36-5/8" 930.3mm	69-3/8" 1762.1mm	24" 609.6mm	5" 127mm	21-5/8" 549.3mm	

**2.2-A INLET AND BYPASS PIPING**

Using Figure 3 as a reference, make the necessary piping connections into the dryer.

Inlet and outlet isolation valves should be installed on the dryer. These valves will aid in the start up and shutdown of the dryer. A bypass valve and piping should also be installed. This will allow the dryer to be taken off stream without interrupting the air system.

**2.2-B OPTIONAL PRESSURE RELIEF VALVE**

A pressure relief valve should be installed to conform to OSHA safety standards. Refer to OSHA Standard Section 1910.169, paragraph "b", subparagraph "3" and any other federal, state or local codes concerning pressure vessels.

A coupling was provided on the upper back side of the vessel for installing the relief valve. A bushing will be necessary to reduce the coupling to the valve inlet size. Reference FIGURE 3 for location.

Listed below are the recommended relief valves available for each dryer. Contact your local Van Air representative to order.

DRYER	VALVE PART NO.	DRYER CONN. SIZE	VALVE SIZE
D-12	14-1462	1" NPT	1/2" NPT
D-16	14-1462	1" NPT	1/2" NPT
D-20	14-1810	2" NPT	3/4" NPT
D-24	14-1800	2" NPT	3/4" NPT
D-30	14-2204	2" NPT	1" NPT
D-36	14-2203	3" NPT	1-1/4" NPT

**2.2-C OPTIONAL GAUGE INSTALLATION**

A coupling was provided on this dryer for the installation of a gauge.

Three gauges are available for this dryer from your Van Air representative.

Thread the gauge kit into the coupling provided on the lower, front side of the vessel as shown in FIGURE 3.

GAUGE KITS	PART NO.
PRESSURE	29-0252
TEMPERATURE	29-0326
COMBINATION PRESSURE/TEMPERATURE	29-0200

**NOTE:** For dryer models D-12 through D-20 only, the gauge coupling can be used for the installation of a high level alarm instead of a gauge.

**2.2-D MANUAL DRAIN VALVE**

A 1" NPT brass ball valve was shipped separately with the dryer. Install the valve on the drain line. Reference FIGURES 3 & 4 for location.

<b>CAUTION</b>
<b>DO NOT CONNECT THE DRAIN TO A PRESSURIZED LINE.</b>
<b>DO NOT INSTALL THE DRAIN LINE IN THE DIRECTION OF PEOPLE AND EQUIPMENT. WHEN THE DRYER IS DRAINED THE DRAIN SOLUTION WILL BE DISCHARGED UNDER LINE PRESSURE. POINTING THE DRAIN IN THE DIRECTION OF PEOPLE AND EQUIPMENT MAY RESULT IN INJURY AND DAMAGE.</b>
<b>DO NOT INSTALL A FLOAT TYPE OR SOLENOID TYPE DRAIN ON THE DRYER. THE DRAIN SOLUTION WILL CAUSE THESE TYPES OF DRAINS TO FAIL, THUS RESULTING IN FLOODING OF THE DRYER.</b>

<b>IMPORTANT</b>
<b>The drain solution may contain lubricants. Comply with all applicable regulations concerning the disposal of these chemicals.</b>

The drain line of the dryer can be remotely piped. DO NOT connect the drain line to a pressurized line. Make sure that the line is vented to atmospheric pressure. Any remote drain piping should be of the same size and on the same level or lower than the drain valve.

When installing the drain line, make sure that the discharge end of the line or valve is directed away from people and equipment.

**2.2-E OPTIONAL AUTOMATIC DRAIN VALVE**

The MDV-400I drain valve is recommended, other materials, sizes, and voltages are available. Contact your local VAN AIR representative to order.

MODEL	VOLT	SIZE	MATERIAL	PART NO.
MDV-400I	115	1" NPT	BRASS	39-2411121

Complete the automatic drain valve installation as shown in FIGURE 2 and outlined in the instructions supplied with the drain. The drain line can be remotely piped, follow the precautions as outlined in Section 2.2-D.

**2.2-F AFTERFILTER**

The installation of an afterfilter prevents any accidental flow of materials from the dryer into the downstream piping.

The afterfilter may be installed before or after the outlet isolation valve. If the afterfilter is installed before the isolation valve, the filter can be isolated from the air system when the dryer is isolated for maintenance.

Below is a chart of VAN AIR recommended filters. Contact your local VAN AIR representative to order.

DRYER	FILTER	DEL-P GAUGE
D-12	F200-100-1-B	PD-5
D-16	F200-150-1-B	PD-5
D-20	F200-265-1-1/4-B	PD-5
D-24	F200-400-2-B	PD-5
D-30	F200-600-3-B	PD-5
D-36	F200-800-3-B	PD-5

**2.2-G DESICCANT INSTALLATION**

<b>IMPORTANT</b>
<b>This dryer was shipped WITHOUT the desiccant installed. The desiccant MUST BE INSTALLED before using the dryer</b>
<b>THE USE OF CHEMICALS OTHER THAN VAN AIR DESICCANT WILL VOID THE WARRANTY ON THE DRYER.</b>

The procedures for filling the dryer with desiccant are outlined in Section 4.4 of this manual.

**2.2-H HIGH LEVEL ALARM HLA-120 (P/N 26-3667)**

The HLA120 high level alarm is designed to alert personnel that the drain solution in the dryer has reached an unacceptable level. A coupling is provided on the dryer models D-24 through D-36. For dryer models D-10 through D-20 the gauge coupling can be used to install the alarm instead of a gauge. Contact your local VAN AIR representative to order.

Install the HLA120 high level alarm in the coupling as shown in FIGURE 3 and as outlined in the instructions supplied with the alarm.

### 3.1 START UP PROCEDURES

Close the inlet and outlet isolation valves. Open the bypass valve and manual drain valve.

Open the outlet isolation valve **SLOWLY** and allow some air to bleed through the manual drain valve; then close the manual drain valve. When the dryer reaches normal operating pressure, **SLOWLY** turn the inlet valve to full open position; then close the bypass valve.

If the vessel was installed without the bypass or isolation valves, **SLOWLY** pressurize the air system. Allow some air to bleed through the manual drain valve. Once the vessel starts to pressurize, the manual drain valve can be closed. Close the bypass valve. The dryer is now on stream.

#### CAUTION

**Make sure that the dryer is not subjected to sudden flow surges. Always open the valves slowly to permit gradual equalization of pressure between the dryer and the air supply lines.**

### 3.2 OPERATING THE DRYER

The simple design of the single tower dryer allows for easy operation. The dryer requires two procedures to ensure peak performance.

#### 3.2-A DAILY DRAINING

The accumulated solution in the bottom of the dryer should be drained at least once every 4 to 8 hours of operation. Depending on actual operating conditions, the dryer may require draining on a more frequent basis.

If an automatic ball valve type drain valve was installed on the dryer, set the time cycle for every 4 to 8 hours. If a manual drain valve was installed, it must be opened at least once every 4 to 8 hours to drain the dryer.

#### CAUTION

**If the dryer is not drained regularly, it may become flooded. Accumulated liquid may enter the air system and cause damage to downstream equipment.**

On a new installation, continue to drain all downstream traps for several days (or until no water is evident) after dryer is installed. This period is required to dry out any accumulated water in the compressed air system. Once the water is removed, the downstream traps should not need to be drained again.

#### 3.2-B REFILLING THE DRYER WITH DESICCANT

During the VAN AIR drying process, the desiccant tablets dissolve slowly. More tablets must be added to the supply when the top of the bed drops to the sight window level (minimum level). Reference FIGURE 5.

The desiccant consumption rate is dependent on several factors, such as inlet temperature, flow, pressure and the type of desiccant being used. With average conditions, the desiccant will usually need to be added only two to three times per year when the dryer is operating one shift per day. However, until the actual usage rate is determined, check the bed level monthly.

Reference Section 4.4-B for estimated consumption rates and refilling instructions.

#### IMPORTANT

**Use VAN AIR desiccant only. Filling dryer with any other material will void the warranty.**

### 3.3 USING THE SIGHT WINDOWS

#### WARNING

**IF THE SIGHT WINDOWS ARE DAMAGED IN ANY WAY, THEY MUST BE REPLACED IMMEDIATELY WITH VAN AIR PART NO. 26-0104 only. REFERENCE SECTION 4.3.**

To check the level of the desiccant bed, look into one of the sight windows. When the top of the desiccant bed is level with the sight windows, the desiccant supply has dropped to the minimum level. The bed must be replenished to raise the bed level to the maximum level.

### 4.1 DAILY PROCEDURES

If an automatic drain valve was not installed on the dryer, the accumulated drain solution from the bottom of dryer must be drained after every 4 to 8 hours of operation. Open manual drain valve and allow the solution to discharge from the dryer; then close the manual drain valve securely.

### 4.2 MONTHLY PROCEDURES

Check the level of the desiccant bed by looking into the sight window. If the top of the desiccant bed is level with the sight window, the desiccant bed must be replenished.

Check the operation of all equipment installed before and after the dryer.

Check the afterfilter element condition. If the pressure differential across the filter is high (6 to 9 PSID), replace the element.

Inspect the hatch cover for signs of corrosion and/or leaks. Replace the cover and/or gasket if necessary.

### 4.3 REPLACING THE SIGHT WINDOWS (P/N 26-0104)

#### WARNING

**DEPRESSURIZE DRYER COMPLETELY BEFORE REMOVING THE SIGHT WINDOW.**

Using a pipe wrench, unthread the old sight window. Remove all pipe sealant, rust or dirt from the coupling.

Apply a layer of pipe sealant to the threads of the new sight window. **DO NOT USE TEFLON TAPE.** Tape may prevent the sight window from threading into the coupling far enough.

## 4.4 ADDITION OF DESICCANT

**WARNING**

**DO NOT REMOVE, REPAIR, OR REPLACE ANY ITEM ON THE DRYER WHILE IT IS UNDER PRESSURE. DEPRESSURIZE THE DRYER COMPLETELY BEFORE STARTING INSTALLATION AND/OR MAINTENANCE PROCEDURES. SERIOUS PERSONAL INJURY MAY RESULT IF THESE SAFETY RULES ARE NOT FOLLOWED.**

**DO NOT REMOVE THE HATCH COVER UNTIL ALL AIR PRESSURE IS OUT OF THE VESSEL. PUSH ON THE HATCH COVER BY HAND TO FIND OUT IF THE VESSEL PRESSURE IS REDUCED TO ZERO.**

**DO NOT TRY TO TIGHTEN THE HATCH COVER IF YOU HEAR OR FEEL A LEAK. IMMEDIATELY SHUT OFF THE AIR OR GAS SUPPLY TO THE VESSEL AND REDUCE THE DRYER PRESSURE TO ZERO.**

**ALWAYS INSTALL A NEW GASKET EVERY TIME THE HATCH COVER IS REMOVED, OR AT LEAST ONCE PER YEAR. REPLACE THE HATCH COVER EVERY FIVE YEARS REGARDLESS OF CONDITION. USE VAN AIR AUTHORIZED PARTS ONLY.**

**DO NOT USE POWER TOOLS OR CHEATER BARS TO TIGHTEN THE NUT ON THE COVER. TOO MUCH FORCE CAN DISTORT THE COVER AND/OR THE GASKET. IF DAMAGED BY OVERTIGHTENING, THE COVER CAN BLOW OUT AND CAUSE SERIOUS INJURY. (Note: Tighten the nut only until it is snug. When pressure is in the vessel, the seal will be complete.)**

**INSPECT THE COVER AND SEALING SURFACE EVERY TIME THE COVER IS REMOVED, OR AT LEAST ONCE PER YEAR, FOR DAMAGE SUCH AS CORROSION, CRACKS, OR DISTORTION. IF THERE IS ANY DAMAGE, INSTALL A NEW COVER AND GASKET. USE VAN AIR AUTHORIZED PARTS ONLY.**

Open the bypass valve. Close the dryer inlet and outlet isolation valves. If the bypass and inlet and outlet isolation valves were not installed, shut down the air system.

Open the drain valve and allow the dryer to depressurize completely.

Loosen the nut on the hatch cover.

Push on the hatch cover. If the vessel is depressurized, the cover will unseal. Once the seal is broken, tilt the hatch cover and remove it from the dryer.

Add the amount of desiccant tablets required to raise the supply to the maximum operating level or to maximum level (see FIGURE 5); then level off the tablet bed.

**CAUTION**

**Make sure that the desiccant does not cover the screen on the outlet pipe.**

**Do NOT overfill the vessel. Adequate space must be left to allow the hatch cover to be installed.**

Check the condition of the hatch cover. If it is damaged, it must be replaced. The gasket should be replaced every time the hatch cover is removed or at least once a year.

Check the sealing surface of the opening. If it is contaminated with dirt or rust, it must be cleaned before installing the hatch cover. A contaminated surface may prevent the gasket from properly sealing.

Install the filler hatch cover and gasket. Finger tighten the nut on the hatch cover. Overtightening will cause damage to the nut. The cover will seal when the vessel is pressurized.

Start up the dryer following the procedures in Section 3.1.

**4.4-A BED LEVEL GUIDE**

To determine the supply of desiccant in the dryer, insert a measuring stick through the filler hatch until it reaches the top of the desiccant bed; dimensions in FIGURE 5 are calculated from the filler hatch to levels indicated on the drawing. (NOTE: Dimensions are approximate and are intended as a general guide only.)

**4.4-B DESICCANT USAGE GUIDE**

The chemical and physical characteristics of Van Air desiccant contribute to its effectiveness and economy.

The DESICCANT CONSUMPTION RATE should be used as a guide to estimate the usage of desiccant your installation will require. The formula is based on an annual usage rate of one shift per day, 5 days per week and 50 weeks per year or 2,000 operating hours per year. The figure is an average and may vary depending upon your actual conditions (i.e. 24 hour operation, higher inlet temperature, excessive liquid water content and/or contaminants.)

**DESICCANT CONSUMPTION**

(Based on 1 shift for a one year period @ 100 psig inlet pressure and 75°F inlet temperature, 100% RH.)

FLOW SCFM	DRY-O-LITE LBS/YEAR	SP LBS/YEAR	10 BF LBS/YEAR
20	26.4	133	115.2
50	66.0	332.5	288.0
100	132.0	665.0	576.0
200	264.0	1330.0	1152.0
300	396.0	1995.0	1728.0
500	660.0	3325.0	2880.0
700	924.0	4655.0	4032.0
1000	1320.0	6650.0	5760.0

To use the chart, first determine the SCFM that is being processed through the dryer. Locate the nearest flow rate listed on the chart and interpolate as necessary.

The consumption rate is proportional to the moisture loading. Each 20°F increase in inlet temperature changes the moisture loading by a factor of nearly 2:1.

The quantity shown in the consumption rate chart is NOT the quantity that must be added to the dryer at one time. The bed level should be maintained at least to the minimum level at all times to ensure optimum drying capabilities. **The consumption rate is an approximation of how much desiccant will be added over a period of one year.**

FIGURE 5 BED LEVEL DETAIL

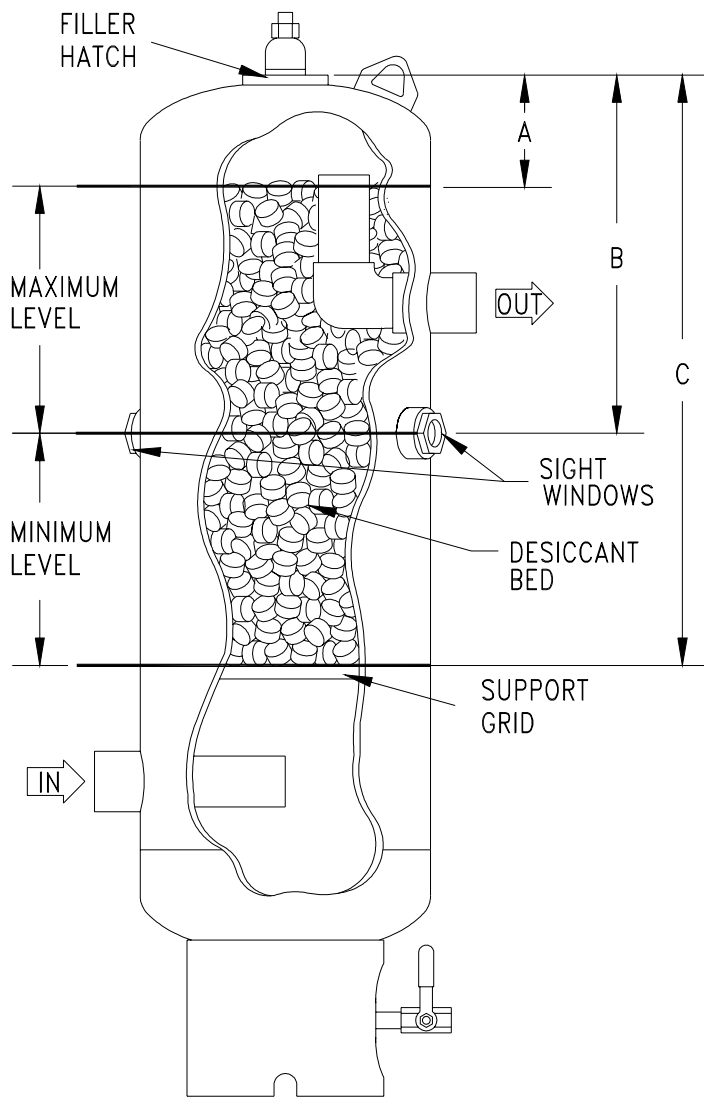

MODEL	BED DIMENSIONS INCHES (centimeters)		
	A MAX. Level	B MIN. Level	C Total Depth
D-12	4.56 <i>11.59</i>	17.63 <i>44.77</i>	30.38 <i>77.15</i>
D-16	5.29 <i>13.34</i>	16.88 <i>42.86</i>	31.19 <i>79.22</i>
D-20	6.38 <i>16.19</i>	16.38 <i>41.59</i>	33.13 <i>84.14</i>
D-24	7.38 <i>18.73</i>	16.94 <i>43.02</i>	33.75 <i>85.73</i>
D-30	9.63 <i>24.45</i>	14.13 <i>35.88</i>	31.88 <i>80.96</i>
D-36	11.31 <i>28.73</i>	17.31 <i>43.97</i>	35.06 <i>89.06</i>

MODEL	DRY-O-LITE QUANTITY* POUNDS (kilograms)				SP or HPD QUANTITY* POUNDS (kilograms)				10 BF QUANTITY* POUNDS (kilograms)			
	Lbs./In of bed**	FILL MIN. Level	FILL MAX Level	MIN to MAX Level	Lbs./In of bed**	FILL MIN. Level	FILL MAX Level	MIN to MAX Level	Lbs./In of bed**	FILL MIN. Level	FILL MAX Level	MIN to MAX Level
D-12	5.22 <i>2.37</i>	66.56 <i>30.19</i>	134.74 <i>61.12</i>	68.19 <i>30.93</i>	3.83 <i>1.74</i>	48.81 <i>22.14</i>	98.82 <i>44.82</i>	50.00 <i>22.68</i>	4.52 <i>2.05</i>	57.68 <i>26.16</i>	116.78 <i>52.97</i>	59.09 <i>26.80</i>
D-16	8.19 <i>3.71</i>	117.22 <i>53.17</i>	212.42 <i>96.35</i>	95.21 <i>43.18</i>	6.01 <i>2.72</i>	85.96 <i>38.99</i>	115.78 <i>52.52</i>	69.82 <i>31.67</i>	7.10 <i>3.22</i>	101.59 <i>46.08</i>	184.10 <i>83.51</i>	82.51 <i>37.43</i>
D-20	12.96 <i>5.88</i>	217.12 <i>98.48</i>	346.73 <i>157.27</i>	129.62 <i>58.79</i>	9.51 <i>4.31</i>	159.22 <i>72.22</i>	254.27 <i>115.33</i>	95.06 <i>43.12</i>	11.23 <i>5.10</i>	188.17 <i>85.35</i>	300.57 <i>136.34</i>	112.34 <i>50.96</i>
D-24	18.43 <i>8.36</i>	309.80 <i>140.52</i>	486.01 <i>220.45</i>	176.21 <i>79.93</i>	13.51 <i>6.13</i>	227.19 <i>103.05</i>	356.41 <i>161.66</i>	129.22 <i>58.61</i>	15.97 <i>7.24</i>	268.50 <i>121.79</i>	421.21 <i>191.06</i>	152.71 <i>69.27</i>
D-30	29.67 <i>13.46</i>	526.56 <i>238.84</i>	660.06 <i>299.40</i>	133.49 <i>60.55</i>	21.76 <i>9.87</i>	386.15 <i>175.15</i>	484.04 <i>219.56</i>	97.90 <i>44.41</i>	25.71 <i>11.66</i>	456.35 <i>207.00</i>	572.05 <i>259.48</i>	115.70 <i>52.48</i>
D-36	44.49 <i>20.18</i>	789.63 <i>358.17</i>	1056.54 <i>479.24</i>	266.92 <i>121.07</i>	32.62 <i>14.80</i>	579.06 <i>262.66</i>	774.80 <i>351.44</i>	195.74 <i>88.79</i>	38.56 <i>17.49</i>	684.34 <i>310.41</i>	915.67 <i>415.34</i>	231.33 <i>104.93</i>

\* Amounts are pounds (kilograms) required to fill dryer to levels indicated.  
 \*\* Amounts in italics are kilograms per centimeter of bed depth.

**1. DECREASED PERFORMANCE - High desiccant usage.****High inlet air temperatures.**

Check the aftercooler performance. Make sure that the aftercooler was properly sized and installed. Check the aftercooler operation manual for further details.

If an aftercooler was not installed, one may be required.

Check the compressor capacity or air usage vs. the dryer rating.

Was a different compressor installed?

**High ambient temperatures.**

Check the location of the dryer for changes in ambient temperatures.

Was the dryer moved to a different location?

Was a piece of equipment or piping installed near the dryer that caused an increase in ambient temperatures? Relocate the dryer or equipment if possible. If relocation is not possible, correct the ambient temperature.

**Dryer overloaded.**

Check the flow through the dryer. Check the flow at peak usage periods. Have the flow requirements of the system increased?

Was the dryer properly sized for the actual operating conditions? Check the capacity of the dryer for the system conditions. If the system requirements exceed the dryer's capability, a larger dryer must be installed.

**Desiccant bed below required level.**

Check the desiccant bed level. The level should be checked at least once a month. The usage of desiccant will vary with the operating conditions and the type of desiccant being used. The dryer will require more desiccant during the warmer months of the year.

Desiccant quantities and filling procedures are outlined in Section 4.4 of this manual.

**2. LIQUID DOWNSTREAM OF THE DRYER.****Improper draining. The dryer may be flooded.**

The dryer must be drained at least once for every 8 hours of operation.

Check the drain valve(s) and piping for clogs. Repair or replace faulty valves. If the piping is clogged, it must be cleared.

If the dryer is installed outdoors where ambient temperatures fall below freezing, the drain line and valve(s) may freeze. If ambient temperatures fall below freezing, the drain line can be wrapped with heat tracing and/or insulation to prevent freezing.

If maintaining the required draining schedule is a problem, an automatic ball type drain valve should be installed. Reference Section 2.2-F in this manual for installation instructions.

**IMPORTANT:** Never install a float type or solenoid type drain valve on this dryer.

**Bypass valve open or faulty.**

Check the dryer bypass valve. It might be faulty or open allowing untreated air to enter the air system.

**Low or no desiccant in the dryer.**

Check the dryer desiccant bed level. Reference Section 4.4 for filling quantities and procedures.

If the above check list does not remedy the problem, consult your local VAN AIR distributor or call the VAN AIR factory in Lake City, Pennsylvania PHONE (814) 774-2631 or FAX (814) 774-3482.

**3. DECREASED PERFORMANCE - low desiccant usage.****The desiccant bed may be contaminated.**

The dryer will tolerate normal amounts of compressor lubricant. If the compressor manufacturer's recommended lubrication rate is exceeded, the desiccant bed can become contaminated with compressor lubricants.

Periodically check the desiccant bed. If the tablets are discolored (deep yellow or brown), the bed may be contaminated.

If the bed has become contaminated, it can be flushed with an adequate supply of water. Depending upon the severity of contamination, it might be necessary to completely flush the entire bed from the dryer and replace it with new desiccant.

Check the compressor for proper operation. The compressor might be worn or over lubricated. Check the compressor operator's manual and correct.

Check the atmospheric air near the compressor air intake. Heavy concentrations of acid fumes or smoke and dust will cause contamination if they are drawn into the air system. Check or install a filter on the compressor intake.

If it is not possible to reduce the amount of lubricants in the air system, a separator and/or coalescing filter should be installed before the dryer.

## SECTION 6

## REPLACEMENT PARTS

ITEM	DESCRIPTION	PART NO.	D12 QTY	D16 QTY	D20 QTY	D24 QTY	D30 QTY	D36 QTY
1	Gasket for 3" x 4" hatch cover	18-0391	1	1	--	--	--	--
	Gasket for 4" x 6" hatch cover	18-0394	--	--	1	1	1	1
2	Hatch Cover, 3" x 4"	46-3002	1	1	--	--	--	--
	Hatch Cover, 4" x 6"	46-3003	--	--	1	1	1	1
3	Sight Window	26-0104	2	2	2	2	2	2
4	Manual Drain Valve 1" NPT	14-0451	1	1	1	1	1	1
5	DESICCANT							
	DRY-O-LITE Desiccant, 50 LB BAG	33-0311	3	4	7	10	13	22
	DRY-O-LITE Desiccant, 506 LB DRUM	33-0203	--	--	--	--	--	--
	SP Desiccant, 50 LB BAG	33-0205	4	4	6	8	10	16
	10BF Desiccant, 25 LB PAIL	33-0232	5	8	12	17	23	37
6	OPTIONAL PRESSURE RELIEF VALVES							
	1/2" NPT 250# set pressure	14-1462	1	1	--	--	--	--
	3/4" NPT 200# set pressure	14-1810	--	--	1	--	--	--
	3/4" NPT 200# set pressure	14-1800	--	--	--	1	--	--
	1" NPT 200# set pressure	14-2204	--	--	--	--	1	--
	1-1/4" NPT 175# set pressure	14-2203	--	--	--	--	--	1
7	OPTIONAL GAUGE KITS							
	Pressure gauge kit	29-0252	1	1	1	1	1	1
	Pressure gauge only	29-0151	1	1	1	1	1	1
	Temperature gauge kit	29-0326	1	1	1	1	1	1
	Temperature gauge only	29-0108	1	1	1	1	1	1
	Thermowell only	29-0107	1	1	1	1	1	1
	Combination pressure/temperature gauge	29-0200	1	1	1	1	1	1
8	OPTIONAL HIGH LEVEL ALRM							
	HLA-120 High level alarm kit	26-3667	--	--	1	1	1	1
	OPTIONAL AUTOMATIC DRAIN VALVE							
9	MDV-400I 1" NPT 115Volt Brass	39-2411121	1	1	1	1	1	1
10	White touch up paint (9 oz. spray can)	45-0152	1	1	1	1	1	1

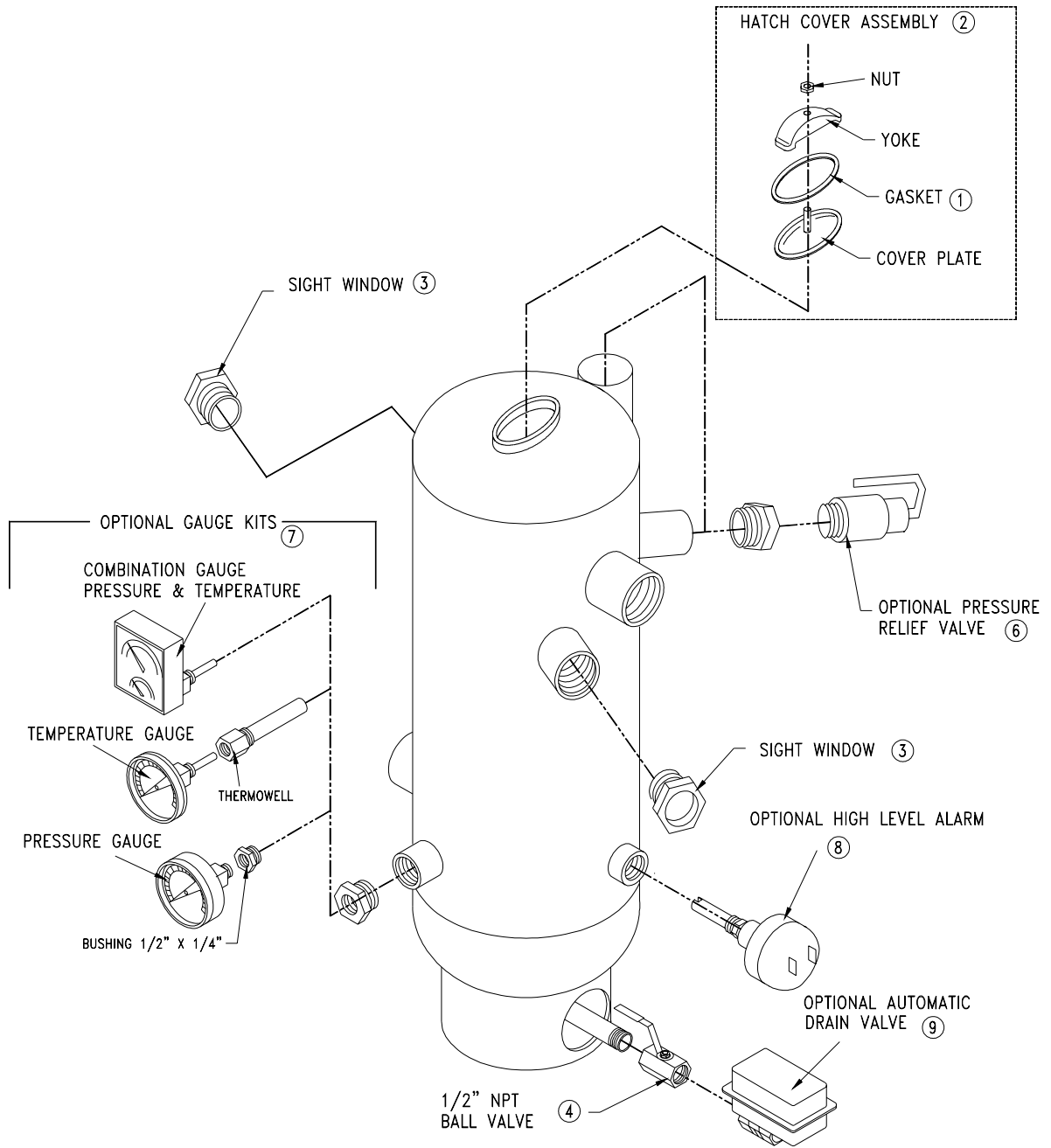

**YOUR VAN AIR REPRESENTATIVE IS:**

**NAME:** \_\_\_\_\_

**COMPANY:** \_\_\_\_\_

**ADDRESS:** \_\_\_\_\_

**CITY:** \_\_\_\_\_ **STATE:** \_\_\_\_\_ **ZIP:** \_\_\_\_\_

**PHONE:** \_\_\_\_\_ **FAX:** \_\_\_\_\_

**ATTACH BUSINESS CARD HERE**

**VAN AIR SYSTEMS INC**

**MAKING COMPRESSED AIR AND GAS WORK BETTER SINCE 1944.**

2950 Mechanic Street  
Lake City, PA 16423-2095  
Phone: 814/774-2631  
Fax: 814/774-3482