

APP'L	DATE	LVL	REVISION
DK	9-9-93	A	ECN 5217
DK	3-14-01	B	ECN 157
	12-7-07	C	ECN 872

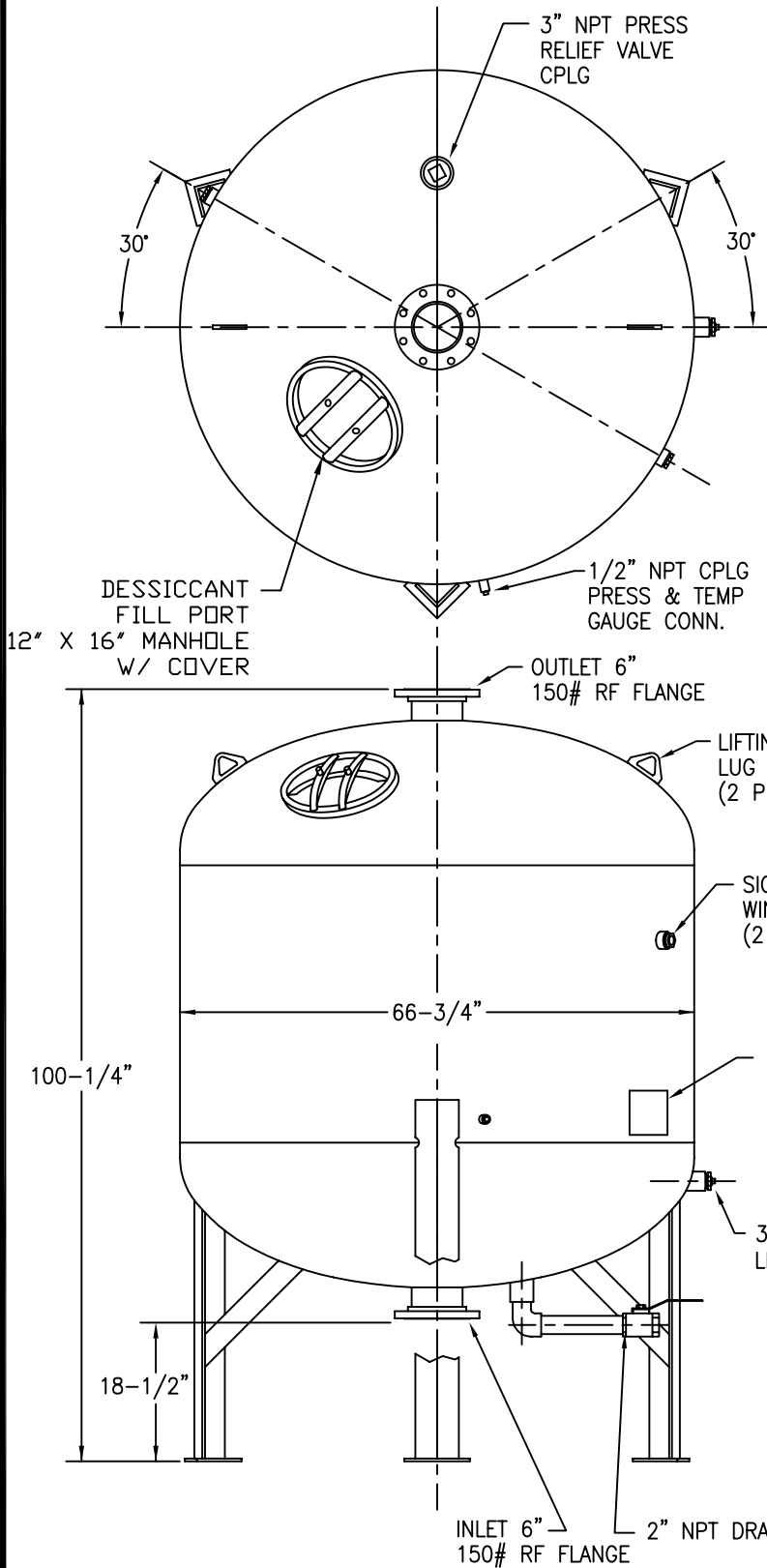

NOTES

- 1) MAXIMUM WORKING PRESSURE: 150 PSIG.
- 2) BUILT TO ASME CODE PLUS CURRENT ADDENDA.
- 3) VESSEL STAMPED "U" SYMBOL.
- 4) TEMPERATURE: -20°F TO 300°F.
- 5) APPROXIMATE WEIGHT EMPTY: 3,200 LBS.
- 6) APPROXIMATE WEIGHT FULL: 7,600 LBS.
- 7) CAPACITY: 918 GALLONS.
- 8) VOLUME: 123 CUBIC FEET.
- 9) INTERIOR PAINT: EPOXY PRIMER, GREY POLYURETHANE FINISH.
- 10) EXTERIOR PAINT: ALKYD GREY PRIMER, WHITE ENAMEL FINISH.
- 11) FLANGE BOLT HOLES TO STRADDLE CENTERLINES.

OPTIONAL EQUIPMENT

- PRESSURE & TEMPERATURE GAUGE KIT.
- HIGH LEVEL ALARM KIT.
- PRESSURE GAUGE KIT.
- TEMPERATURE GAUGE KIT.

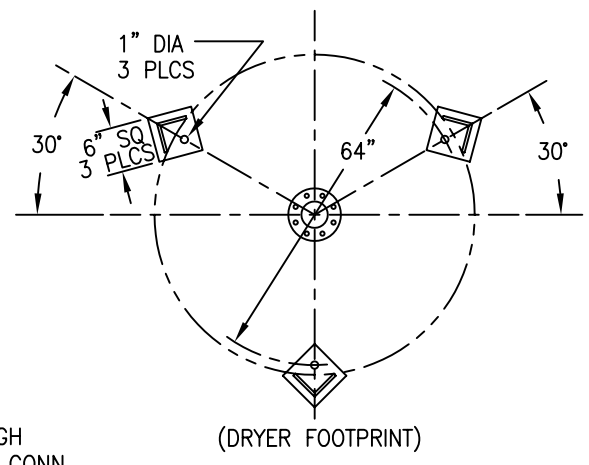

P/N 80-0015

This drawing is the property of **VAN AIR SYSTEMS INC** and is subject to return upon request. It shall not be copied or duplicated in any manner and shall not be submitted to outside parties for examination without the consent of Van Air Systems Inc. It shall be used for reference to work under contract or proposals submitted by Van Air Systems Inc. only.

**DELIQUESCENT DRYER**  
**D-66**

DRWN BY: MJM	DATE: 9-9-93	DRWG No.	REV
CHECKED: DK	SCALE: NONE	SD-11656	C

APPL: DK

**VAN AIR SYSTEMS INC**

Lake City, PA 16423 (814)774-2631 Fax: 814/774-3482 Telex: 91-4548