

**SPECIFICATIONS:**  
1. CAPACITY:

	COMPRESSOR OUTPUT IN SCFM/ COMPRESSOR HORSEPOWER		
	MINERAL OIL	PAO/DIESTER OIL	SYNTHETIC OIL
SCREW & ROTARY COMPRESSORS W/ OIL INJECTION COOLING	450/100	338/75	225/50
PISTON COMPRESSOR 1 & 2 STAGE	338/75	————	225/50

SCREW & ROTARY COMPRESSORS W/ OIL INJECTION COOLING

FRESH OIL LUBRICATED ROTARY COMPRESSORS AND MULTI-STAGE PISTON COMPRESSORS HAVE A GREATER TENDENCY TOWARD EMULSIFICATION. CONDENSATE DISCHARGE CONTAINING STABLE EMULSIONS WILL REQUIRE THE USE OF A MORE SOPHISTICATED TYPE OF SEPARATOR THAT CAN EFFECTIVELY SEPARATE STABLE EMULSIONS.

PISTON COMPRESSOR 1 & 2 STAGE

ROTARY COMPRESSOR W/ FRESH OIL DRIP FEED LUBRICATION

PISTON COMPRESSOR 3, 4 & 5 STAGE

2. FLUID CAPACITIES:

- \*HOUSING (MAX): 17.73 GAL.
- \*HOUSING (FILL): 12.46 GAL. \*CARBON FILTER: 10.65 GAL.

3. WEIGHTS:

- \*UNIT (EMPTY): 19.5 LBS.
- \*UNIT (MAX FULL): 167 LBS.

4. CONDENSATE TEMPERATURE: RANGE. 41°F TO 140°F.

5. QUIK-PURE OIL/WATER SEPARATORS ARE NOT DESIGNED TO SEPARATE STABLE OIL/WATER EMULSIONS.

6. ACCESSORIES & REPLACEMENT PARTS:

- \*MULTIPLE INLET ADAPTER: (P/N 26-7216), FOR USE IN CONNECTING UP TO 3 UNITS TOGETHER.
- \*REPLACEMENT FILTER SET: (P/N 26-7212) SET INCLUDES (1) PREFILTER & (1) ACTIVATED CARBON FILTER.
- \*FLOW SPLITTER KIT: (P/N 26-7215)
- \*HIGH PRESSURE RELIEF CHAMBER: (P/N 26-7218)
- \*OTHER REPLACEMENT PARTS AVAILABLE.

APP'L	DATE	LVL	ECN

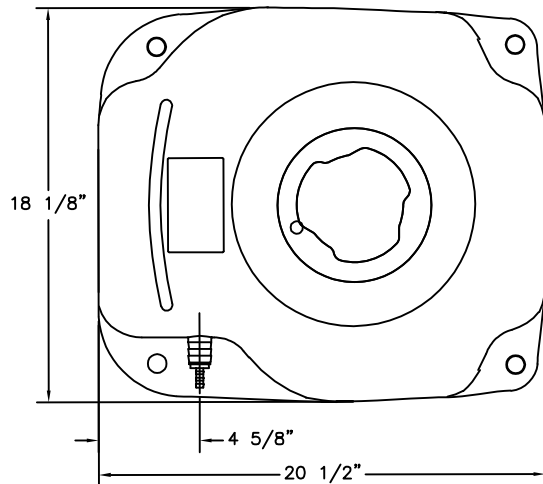

WATER OUTLET  
1" HOSE BARB

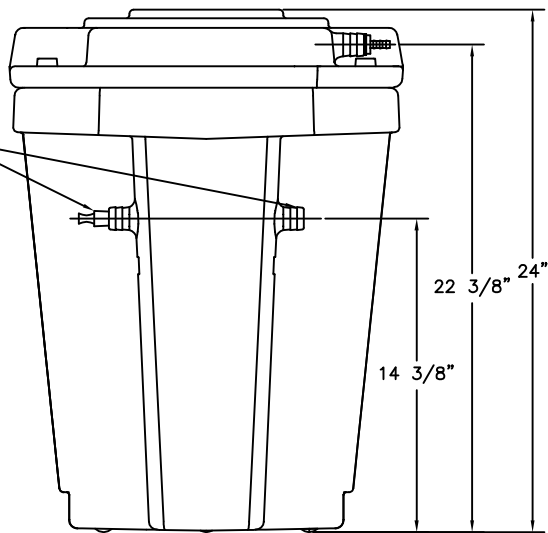

CONDENSATE INLET  
1/2" OR 1" HOSE BARB  
(MUST NOT REMOVE 1/2"  
CONNECTOR NOT EVEN WHEN  
USING 1" HOSE)

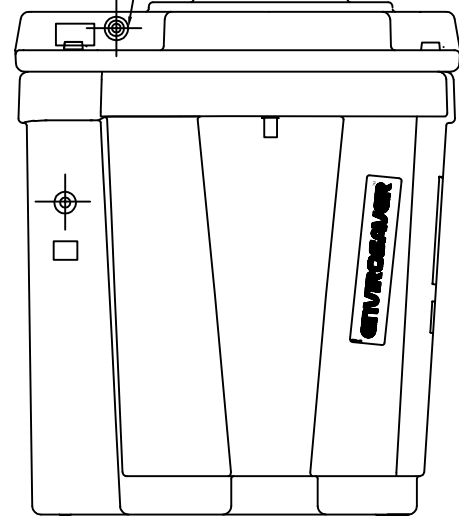

P/N: 85-10010

THIS DRAWING IS THE PROPERTY OF  
**VAN AIR INC.**

AND IS SUBJECT TO RETURN UPON REQUEST. IT SHALL NOT BE COPIED OR DUPLICATED IN ANY MANNER AND SHALL NOT BE SUBMITTED TO OUTSIDE PARTIES FOR EXAMINATION WITHOUT THE CONSENT OF VAN AIR INC. IT SHALL BE USED FOR REFERENCE TO WORK UNDER CONTRACT OR PROPOSALS SUBMITTED BY VAN AIR INC. ONLY.

**OIL WATER SEPARATOR  
ENVIROSAVER QP-100**

DRWN BY: JMY	DATE: 06-15-09	DRWG No.	SD-14439	REV
CHECKED:	SCALE: NONE			
APP'L:	<b>VAN AIR SYSTEMS</b>			