

**SPECIFICATIONS:**

**1. CAPACITY:**

SCREW & ROTARY COMPRESSORS W/ OIL INJECTION COOLING

COMPRESSOR OUTPUT IN SCFM/ COMPRESSOR HORSEPOWER		
MINERAL OIL	PAO/DIESTER OIL	SYNTHETIC OIL
113/25	90/20	60/15
90/20	—	60/15

PISTON COMPRESSOR 1 & 2 STAGE

ROTARY COMPRESSOR W/ FRESH OIL DRIP FEED LUBRICATION

PISTON COMPRESSOR 3, 4 & 5 STAGE

FRESH OIL LUBRICATED ROTARY COMPRESSORS AND MULTI-STAGE PISTON COMPRESSORS HAVE A GREATER TENDENCY TOWARD EMULSIFICATION. CONDENSATE DISCHARGE CONTAINING STABLE EMULSIONS WILL REQUIRE THE USE OF A MORE SOPHISTICATED TYPE OF SEPARATOR THAT CAN EFFECTIVELY SEPARATE STABLE EMULSIONS.

**2. FLUID CAPACITIES:**

- \*HOUSING (MAX): 2.64 GAL. \*PREFILTER: 0.66 GAL.
- \*HOUSING (FILL): 1.14 GAL. \*CARBON FILTER: 0.53 GAL.

**3. WEIGHTS:**

- \*UNIT (EMPTY): 7.7 LBS.
- \*UNIT (MAX FULL): 30 LBS.

**4. CONDENSATE TEMPERATURE: RANGE. 41°F TO 140°F.**

**5. QUIK-PURE OIL/WATER SEPARATORS ARE NOT DESIGNED TO SEPARATE STABLE OIL/WATER EMULSIONS.**

**6. ACCESSORIES & REPLACEMENT PARTS:**

- \*REPLACEMENT FILTER SET: (P/N 26-7211) SET INCLUDES (1) PREFILTER & (1) ACTIVATED CARBON FILTER.
- \*FLOW SPLITTER KIT: (P/N 26-7215)
- \*HIGH PRESSURE RELIEF CHAMBER: (P/N 26-7218)
- \*OTHER REPLACEMENT PARTS AVAILABLE.

APP'L	DATE	LVL	ECN

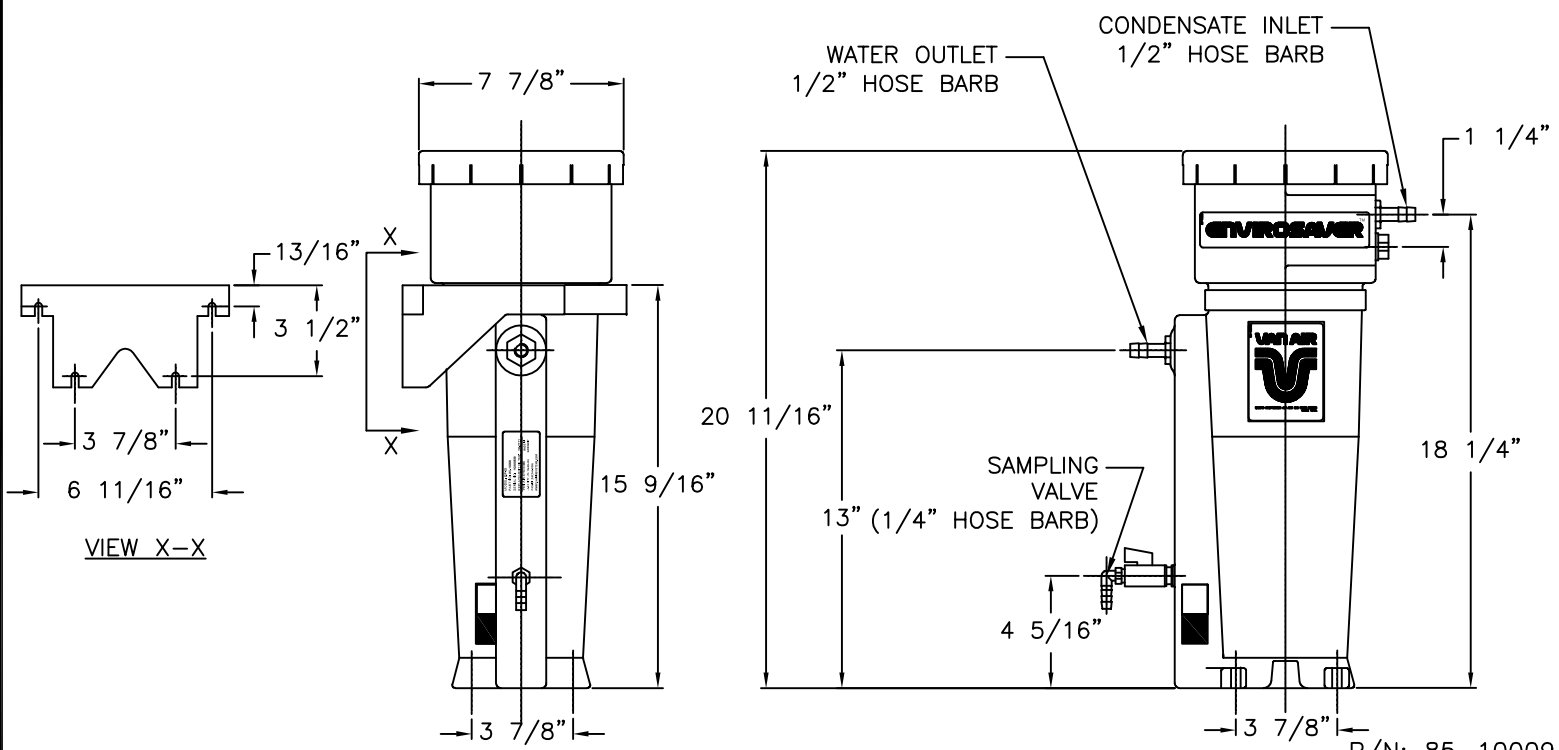
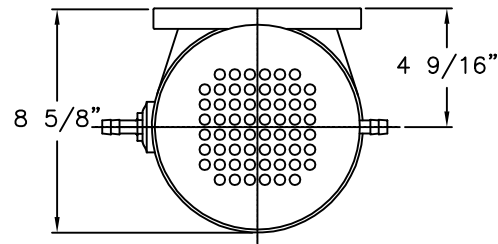

P/N: 85-10009

THIS DRAWING IS THE PROPERTY OF

**VAN AIR INC.**

AND IS SUBJECT TO RETURN UPON REQUEST. IT SHALL NOT BE COPIED OR DUPLICATED IN ANY MANNER AND SHALL NOT BE SUBMITTED TO OUTSIDE PARTIES FOR EXAMINATION WITHOUT THE CONSENT OF VAN AIR INC. IT SHALL BE USED FOR REFERENCE TO WORK UNDER CONTRACT OR PROPOSALS SUBMITTED BY VAN AIR INC. ONLY.

**OIL WATER SEPARATOR  
ENVIROSAVER QP-25**

DRWN BY: JMY	DATE: 06-12-09	DRWG No. SD-14438	REV
CHECKED:	SCALE: NONE		

APP'L: **VAN AIR SYSTEMS**  
 A DIVISION OF VAN AIR INC. LAKE CITY, PA 16423 (814)774-2631 FAX:(814)774-4065