

SPECIFICATIONS:

1. CAPACITY:

	COMPRESSOR OUTPUT IN SCFM/ COMPRESSOR HORSEPOWER		
	MINERAL OIL	PAO/DIESTER OIL	SYNTHETIC OIL
SCREW & ROTARY COMPRESSORS W/ OIL INJECTION COOLING	1575/350	1125/250	788/175
PISTON COMPRESSOR 1 & 2 STAGE	1125/250	————	495/110

2. FLUID CAPACITIES:

- *HOUSING (MAX): 60.34 GAL. *PRE-FILTER: 9.60 GAL.
- *HOUSING (FILL): 36.24 GAL. *CARBON FILTER: 10.65 GAL.

3. WEIGHTS:

- *UNIT (EMPTY): 92.6 LBS.
- *UNIT (MAX FULL): 596 LBS.

4. CONDENSATE TEMPERATURE: RANGE. 41°F TO 140°F.

5. QUIK-PURE OIL/WATER SEPARATORS ARE NOT DESIGNED TO SEPARATE STABLE OIL/WATER EMULSIONS.

6. ACCESSORIES & REPLACEMENT PARTS:

- *MULTIPLE INLET ADAPTER: (P/N 26-7216), FOR USE IN CONNECTING UP TO 3 UNITS TOGETHER.
- *REPLACEMENT FILTER SET: (P/N 26-7214) SET INCLUDES (1) PREFILTER & (1) ACTIVATED CARBON FILTER.
- *ALARM SENSOR FOR LEVEL INDICATOR (P/N 26-7217)
- *FLOW SPLITTER KIT: (P/N 26-7215)
- *HIGH PRESSURE RELIEF CHAMBER: (P/N 26-7218)
- *HEATER 230V (P/N 26-7222)
- *OTHER REPLACEMENT PARTS AVAILABLE.

FRESH OIL LUBRICATED ROTARY COMPRESSORS AND MULTI-STAGE PISTON COMPRESSORS HAVE A GREATER TENDENCY TOWARD EMULSIFICATION. CONDENSATE DISCHARGE CONTAINING STABLE EMULSIONS WILL REQUIRE THE USE OF A MORE SOPHISTICATED TYPE OF SEPARATOR THAT CAN EFFECTIVELY SEPARATE STABLE EMULSIONS.

APP'L	DATE	LVL	ECN

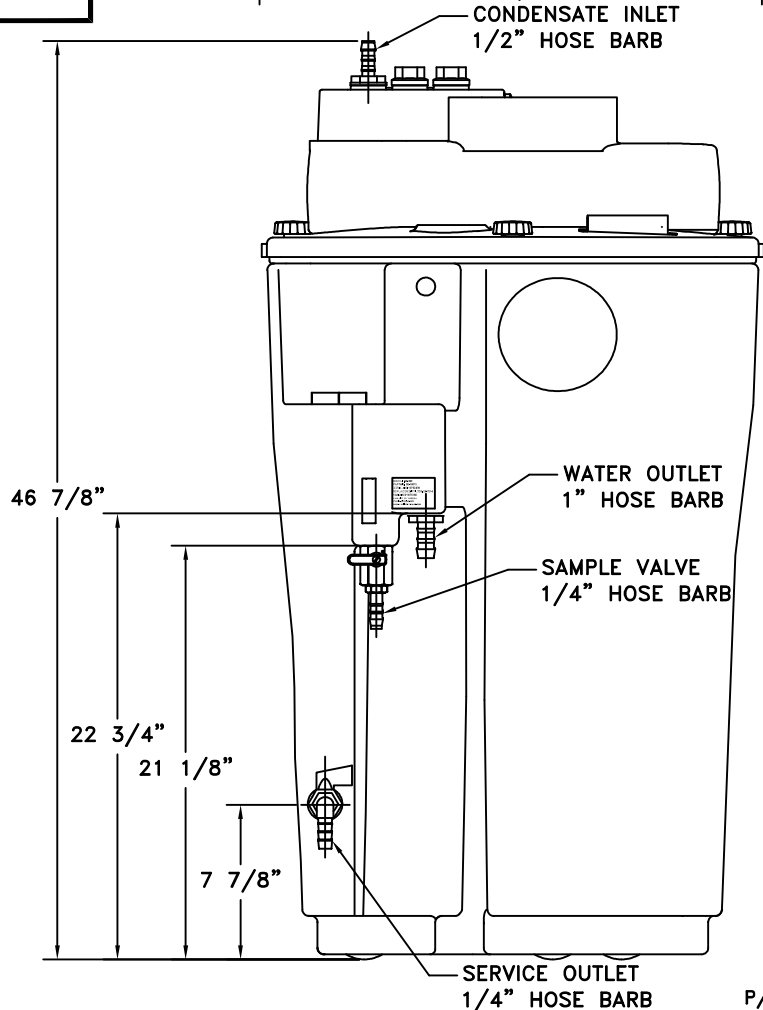
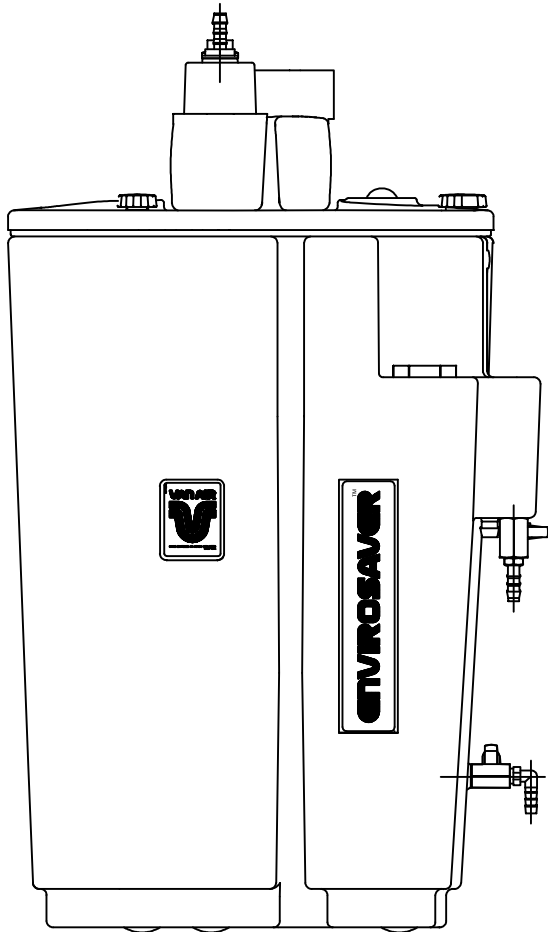
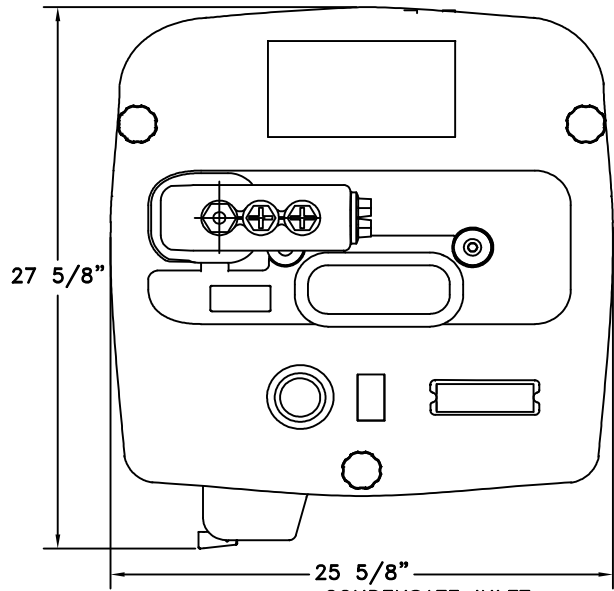

P/N: 85-10012

THIS DRAWING IS THE PROPERTY OF

VAN AIR INC.

AND IS SUBJECT TO RETURN UPON REQUEST. IT SHALL NOT BE COPIED OR DUPLICATED IN ANY MANNER AND SHALL NOT BE SUBMITTED TO OUTSIDE PARTIES FOR EXAMINATION WITHOUT THE CONSENT OF VAN AIR INC. IT SHALL BE USED FOR REFERENCE TO WORK UNDER CONTRACT OR PROPOSALS SUBMITTED BY VAN AIR INC. ONLY.

**OIL WATER SEPARATOR
ENVIROSAVER QP-350**

DRWN BY: JMY	DATE: 06-15-09	DRWG No. SD-14441	REV
CHECKED:	SCALE: NONE		
APP'L:	VAN AIR SYSTEMS		