

**NOTES:**

- 1) SYSTEM MAXIMUM WORKING PRESSURE: 200 PSIG.
- 2) SYSTEM INLET RATING: 1200 SCFM @ 100 PSIG, 180°F. (SIZED FOR 90°F AMBIENT, AND A 10°F APPROACH).
- 3) DRYER VESSEL BUILT TO THE CURRENT EDITION OF THE ASME CODE SECTION VIII, DIV 1.
- 4) DRYER VESSEL IS STAMPED: "U" DESIGNATOR.
- 5) DRYER VESSEL INTERIOR IS COATED WITH A ZINC FORTIFIED EPOXY PRIMER AND A URETHANE TOP COAT. SYSTEM EXTERIOR (EXCLUDING COOLER CORE) IS COATED WITH EPOXY PRIMER AND BLUE POLYURETHANE FINISH COAT.
- 6) DRYER VESSEL HAS A 1/16" CORROSION ALLOWANCE.
- 7) APPROXIMATE WEIGHT OF UNIT: 1390 LBS (EMPTY).
- 8) A 2" NPT COUPLING FOR A PRESSURE RELIEF VALVE CONNECTION, IS LOCATED ON THE BACK OF THE DRYER VESSEL.
- 9) AIR MOTOR REQUIRES 33 SCFM @ 30 PSIG TO OBTAIN 1725 RPM FAN SPEED.
- 10) UNIT SUPPLIED WITH INITIAL DESICCANT FILL: 750# OF DRY-O-LITE (15 BAGS) SHIPPED SEPARATELY (CUSTOMER TO INSTALL).

APP'L	DATE	LVL	ECN

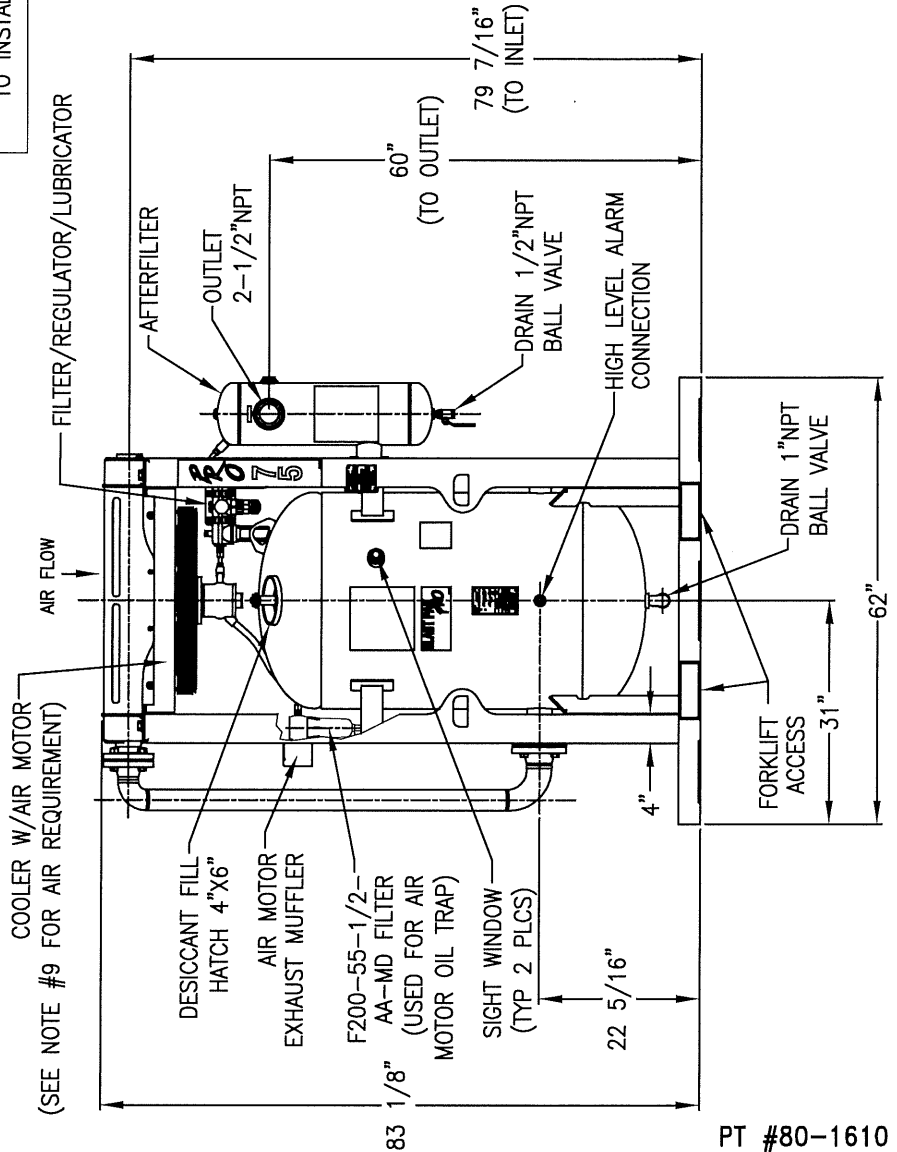
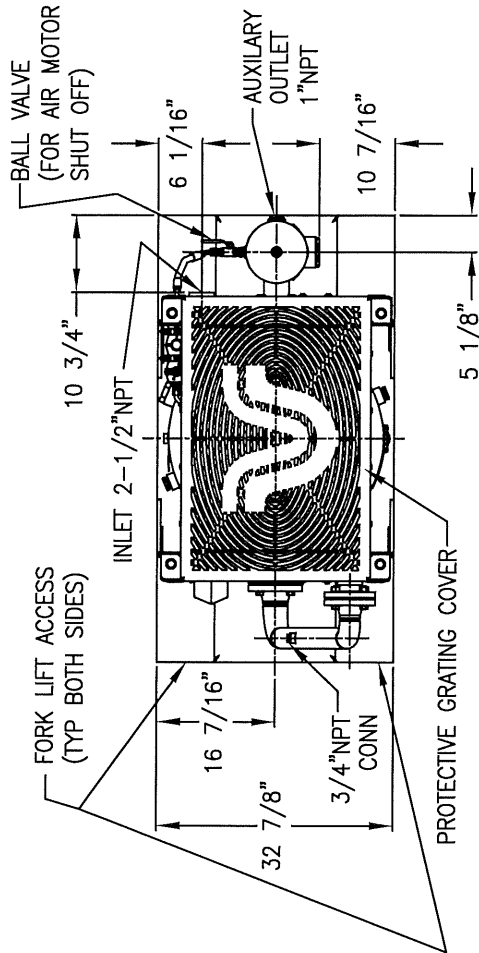

PT #80-1610

THIS DRAWING IS THE PROPERTY OF

**VAN AIR INC.**

AND IS SUBJECT TO RETURN UPON REQUEST. IT SHALL NOT BE COPIED OR DUPLICATED IN ANY MANNER AND SHALL NOT BE SUBMITTED TO OUTSIDE PARTIES FOR EXAMINATION WITHOUT THE CONSENT OF VAN AIR INC. IT SHALL BE USED FOR REFERENCE TO WORK UNDER CONTRACT OR PROPOSALS SUBMITTED BY VAN AIR INC. ONLY.

**BLAST PAK  
PRO-75 GEN 2**

DRWN BY: KLK	DATE: 4-5-19	DRWG No. SD-14861	REV
CHECKED: <i>JK</i>	SCALE: NONE		

APP'L: *JK*

**VAN AIR SYSTEMS**

A DIVISION OF VAN AIR INC. LAKE CITY, PA 16423 (814)774-2631 FAX:(814)774-4065