

APP'L	DATE	LVL	REVISION
SCF	02-01-96	A	ECN:5451
SCF	06-28-96	B	ECN:NO725
SCF	04-09-98	C	ECN:NO829
	10-28-02	D	ECN: 276

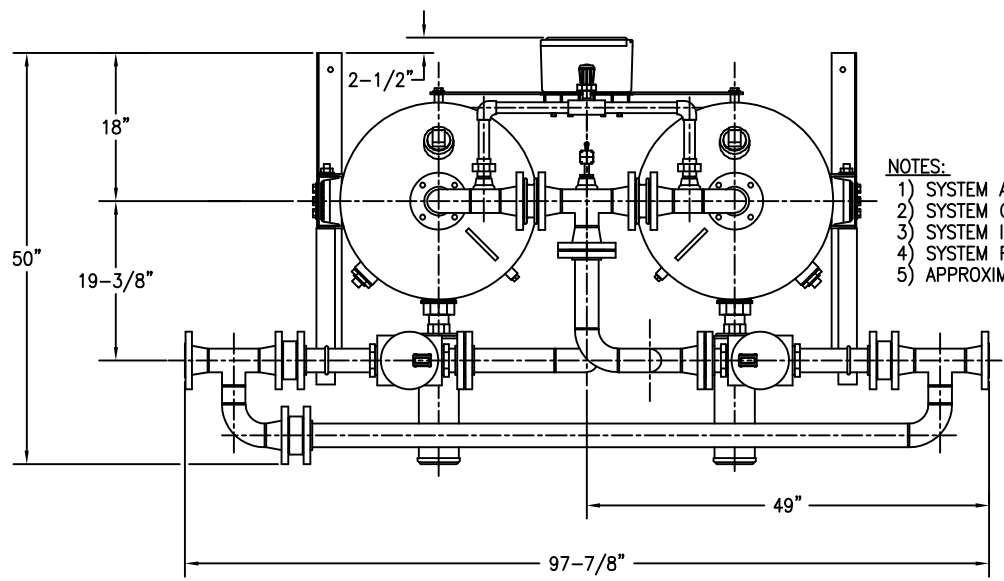

- NOTES:
- 1) SYSTEM AMBIENT OPERATING TEMPERATURE RANGE: 40°F TO 120°F.
 - 2) SYSTEM OPERATING PRESSURE RANGE: 60 PSIG TO 150 PSIG.
 - 3) SYSTEM INLET OPERATING TEMPERATURE RANGE: 40°F TO 120°F.
 - 4) SYSTEM RATED FLOW: 1000 SCFM @ 100 PSIG, 100°F.
 - 5) APPROXIMATE WEIGHT OF UNIT: 1940 LBS (WITHOUT DESICCANT).
: 3060 LBS (WITH DESICCANT).

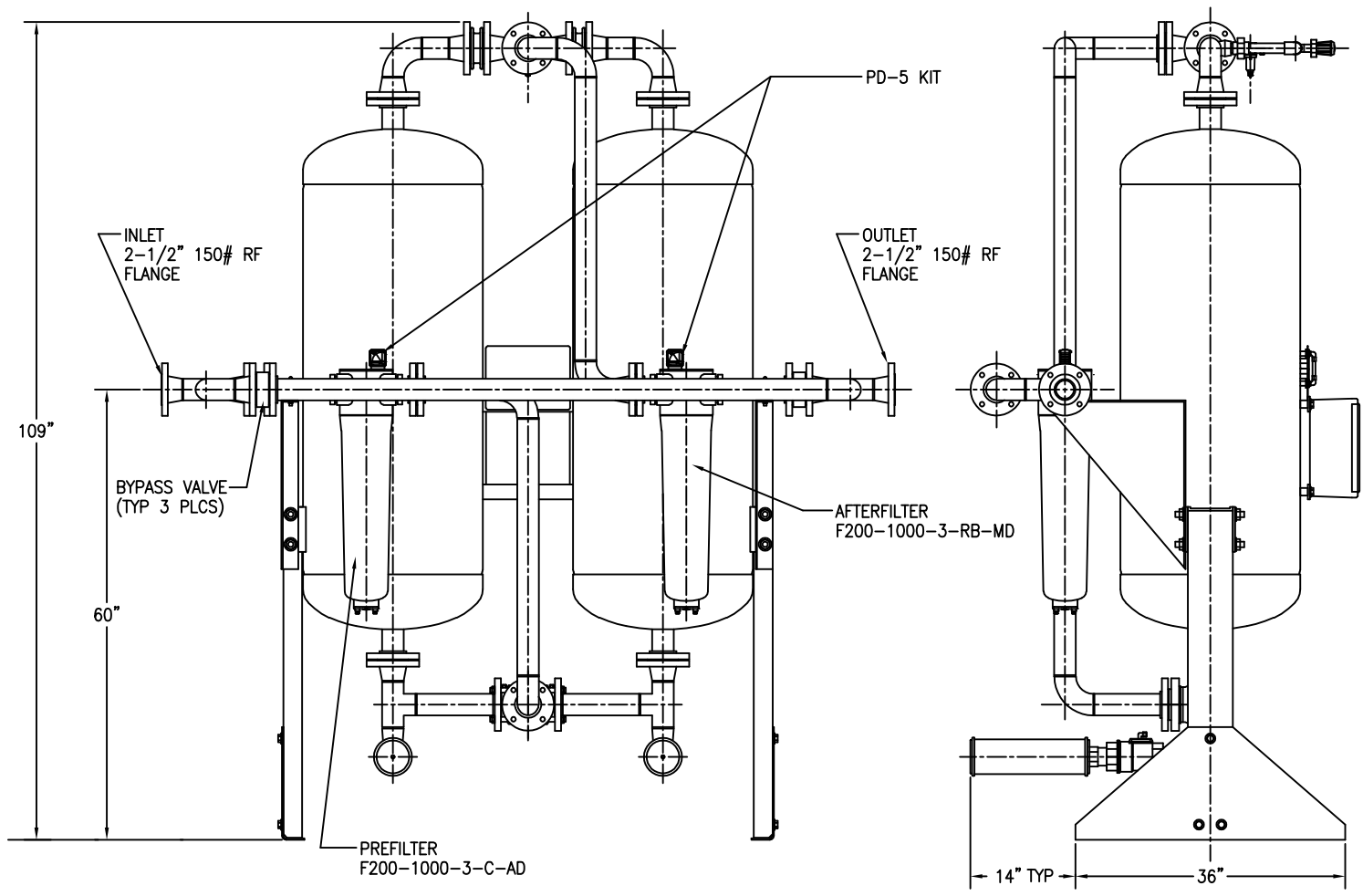

This drawing is the property of **VAN AIR SYSTEMS INC** and is subject to return upon request. It shall not be copied or duplicated in any manner and shall not be submitted to outside parties for examination without the consent of Van Air Systems Inc. It shall be used for reference to work under contract or proposals submitted by Van Air Systems Inc. only.

HEATLESS REGENERATIVE DRYER HL-1000 WITH MOUNTED FILTERS AND 3 VALVE BYPASS

DRWN BY: JMK	DATE: 05-15-95	DRWG No. SD-13101	REV D
CHECKED:	SCALE: NONE		

APPL: **VAN AIR SYSTEMS INC**
 Lake City, PA 16423 (814)774-2631 Fax: 814/774-3482 Telex: 91-4548