

APP'L	DATE	LVL	REVISION
	10-28-02	A	ECN: 276

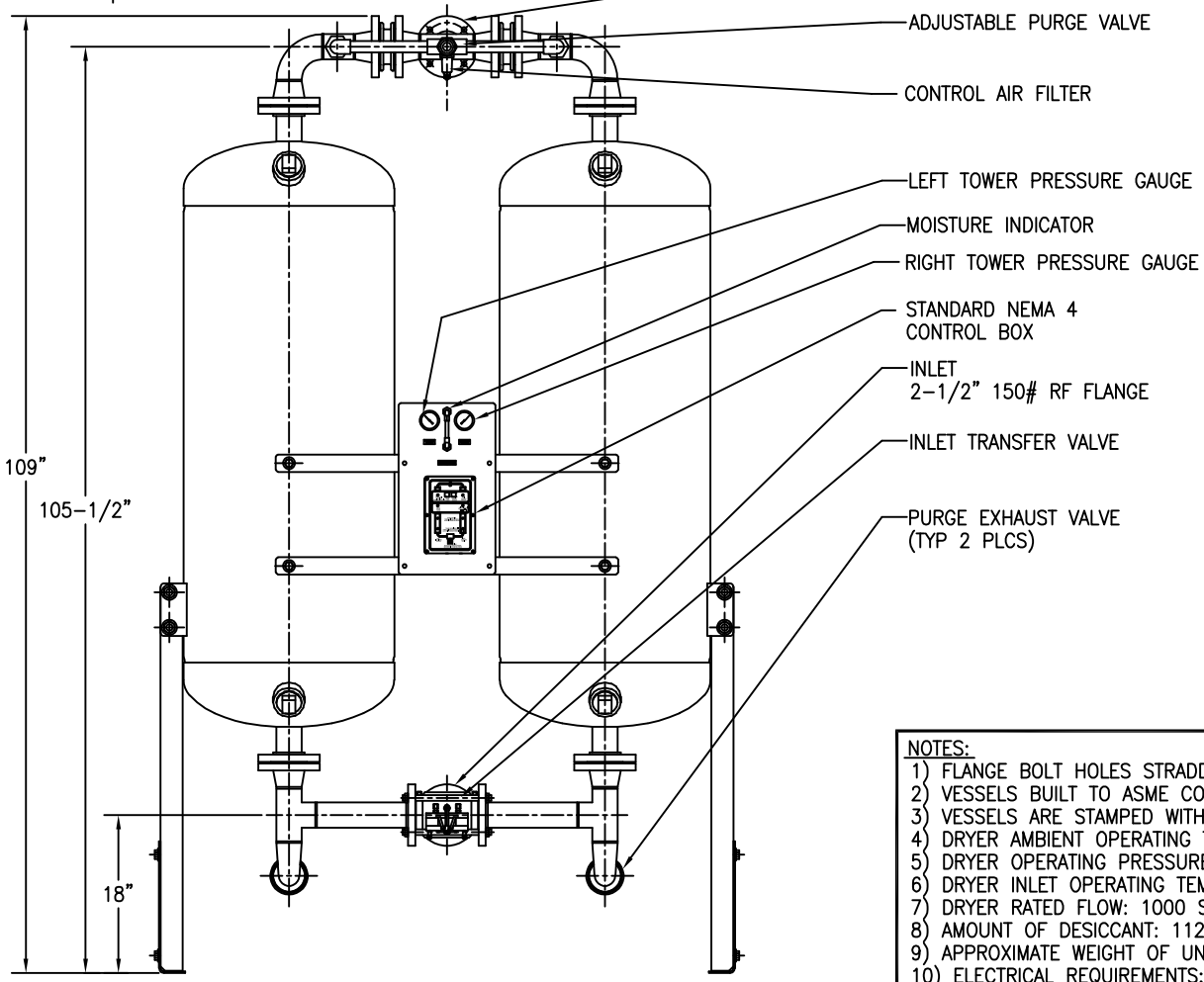
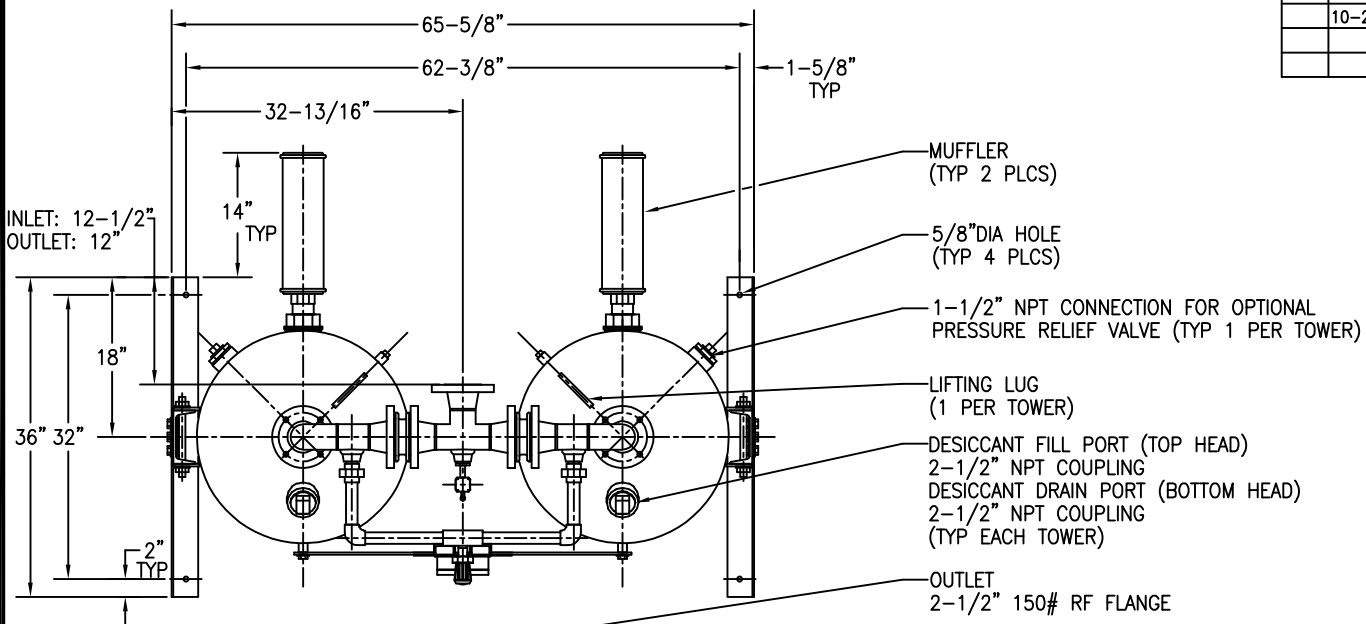

- NOTES:
- 1) FLANGE BOLT HOLES STRADDLE CENTERLINES.
 - 2) VESSELS BUILT TO ASME CODE PLUS CURRENT ADDENDA.
 - 3) VESSELS ARE STAMPED WITH "U" SYMBOL.
 - 4) DRYER AMBIENT OPERATING TEMP. RANGE: 40°F TO 120°F.
 - 5) DRYER OPERATING PRESSURE RANGE: 60 TO 150 PSIG.
 - 6) DRYER INLET OPERATING TEMP. RANGE: 40°F TO 120°F.
 - 7) DRYER RATED FLOW: 1000 SCFM @ 100 PSIG, 100°F.
 - 8) AMOUNT OF DESICCANT: 1120 LBS (560 LBS PER TOWER).
 - 9) APPROXIMATE WEIGHT OF UNIT: 1510 LBS.(W/O DESICCANT)
 - 10) ELECTRICAL REQUIREMENTS: 115V/1PH/60HZ, .3 AMP.

This drawing is the property of **VAN AIR SYSTEMS INC** and is subject to return upon request. It shall not be copied or duplicated in any manner and shall not be submitted to outside parties for examination without the consent of Van Air Systems Inc. It shall be used for reference to work under contract or proposals submitted by Van Air Systems Inc. only.

HEATLESS REGENERATIVE DRYER HL-1000

DRWN BY: TEK	DATE: 04-08-98	DRWG No.	SD-13565	REV
CHECKED:	SCALE: NONE			A

APPL: **VAN AIR SYSTEMS INC**

Lake City, PA 16423 (814)774-2631 Fax: 814/774-3482 Telex: 91-4548