

APP'L	DATE	LVL	REVISION
SCF	02-01-96	A	ECN:5452
SCF	04-09-98	B	ECN:N0829
	10-28-02	C	ECN: 276

**NOTES:**

- 1) SYSTEM AMBIENT OPERATING TEMPERATURE RANGE: 40°F TO 120°F.
- 2) SYSTEM OPERATING PRESSURE RANGE: 60 PSIG TO 150 PSIG.
- 3) SYSTEM INLET OPERATING TEMPERATURE RANGE: 40°F TO 120°F.
- 4) SYSTEM RATED FLOW: 1250 SCFM @ 100 PSIG, 100°F.
- 5) APPROXIMATE WEIGHT OF UNIT: 2550 LBS (WITHOUT DESICCANT).  
: 3906 LBS (WITH DESICCANT).

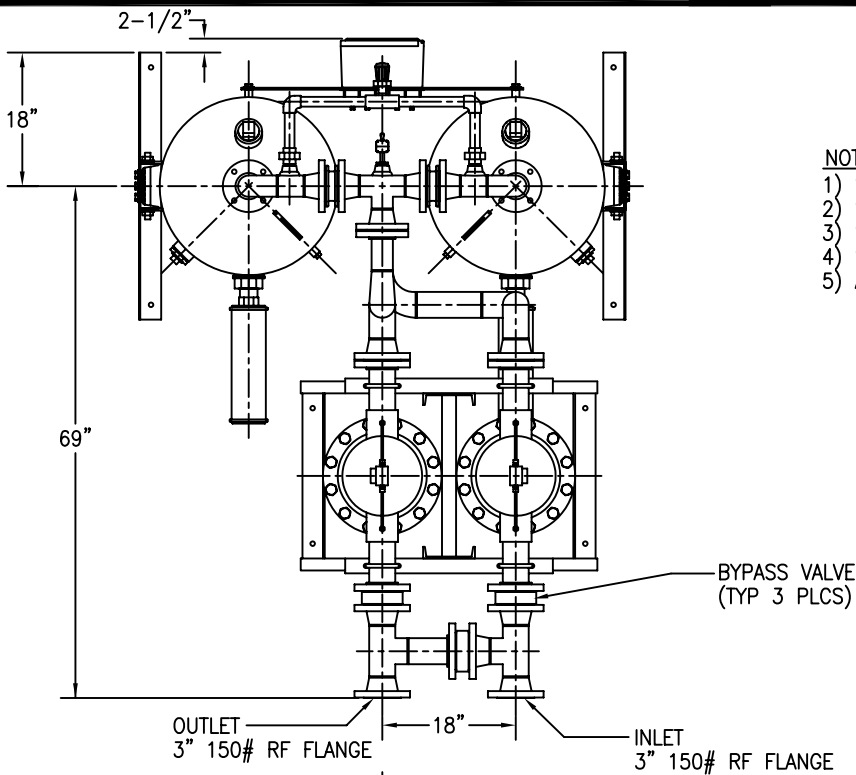

INLET AND OUTLET PIPING CONNECTION RUNS ARE SHIPPED LOOSE. THEY MUST BE BOLTED BETWEEN THE DRYER AND FILTER SKID AT INSTALLATION. ALL FASTENERS AND GASKETS ARE SUPPLIED.

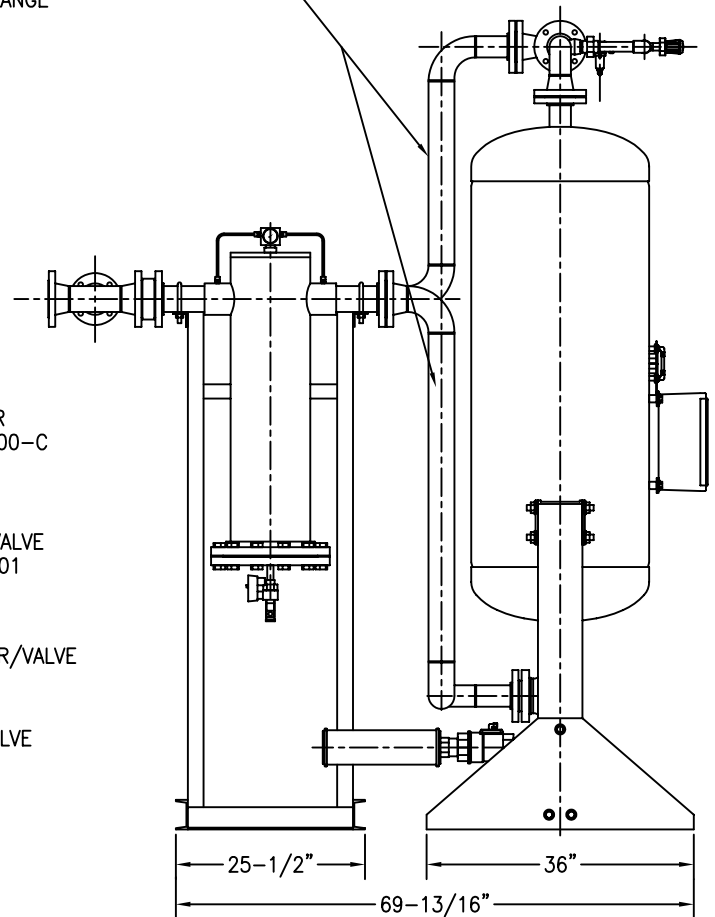
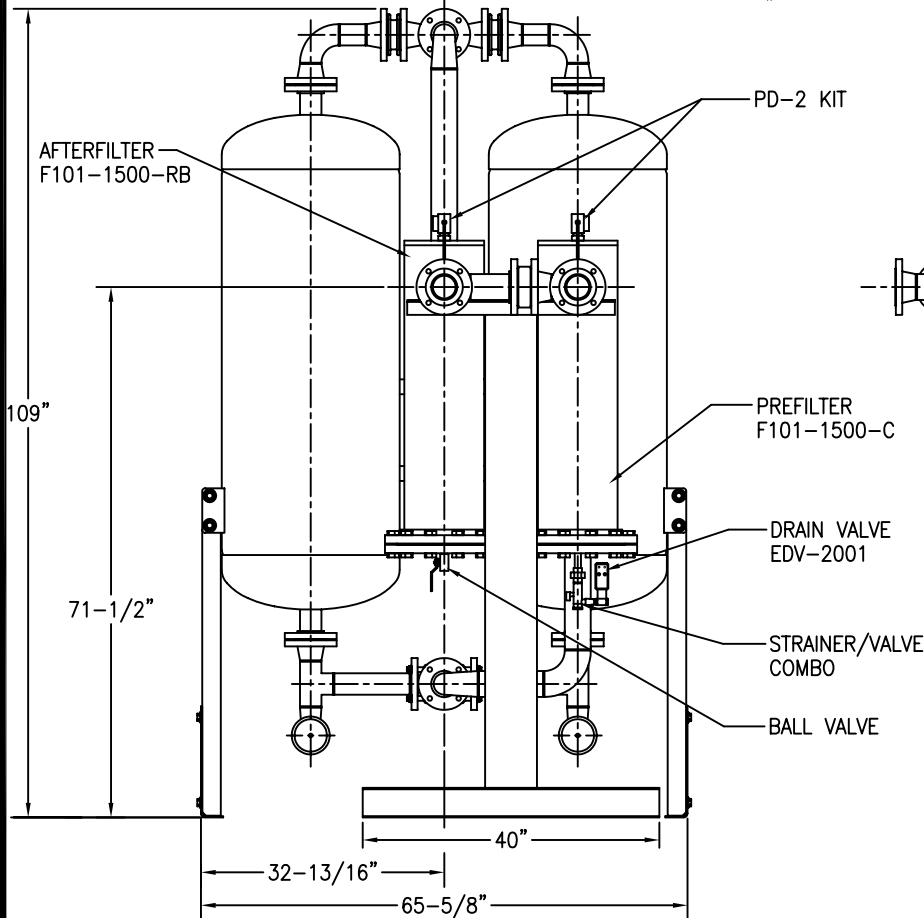

This drawing is the property of

**VAN AIR SYSTEMS INC**

and is subject to return upon request. It shall not be copied or duplicated in any manner and shall not be submitted to outside parties for examination without the consent of Van Air Systems Inc. It shall be used for reference to work under contract or proposals submitted by Van Air Systems Inc. only.

## HEATLESS REGENERATIVE DRYER HL-1250 WITH MOUNTED FILTERS AND 3 VALVE BYPASS

DRWN BY: <b>JMK</b>	DATE: <b>05-15-95</b>	DRWG No. <b>SD-13103</b>	REV <b>C</b>
CHECKED:	SCALE: NONE		

APPL:

**VAN AIR SYSTEMS INC**

Lake City, PA 16423 (814)774-2631 Fax: 814/774-3482 Telex: 91-4548