

APP'L	DATE	LVL	REVISION
SCF	02-01-96	A	ECN:5453
	04-09-98	B	ECN:N0829

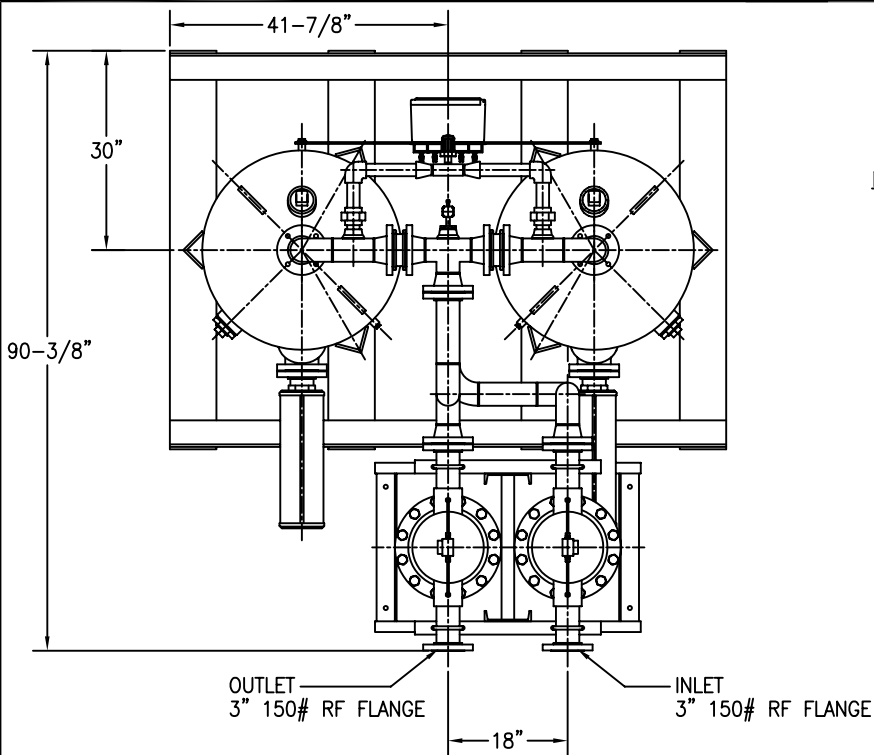

NOTES:

- 1) SYSTEM AMBIENT OPERATING TEMPERATURE RANGE: 40°F TO 120°F.
- 2) SYSTEM OPERATING PRESSURE RANGE: 60 PSIG TO 150 PSIG.
- 3) SYSTEM INLET OPERATING TEMPERATURE RANGE: 40°F TO 120°F.
- 4) SYSTEM RATED FLOW: 1500 SCFM @ 100 PSIG, 100°F.
- 5) APPROXIMATE WEIGHT OF UNIT: 3040 LBS (WITHOUT DESICCANT).
: 4784 LBS (WITH DESICCANT).

INLET AND OUTLET PIPING CONNECTIONS RUNS ARE SHIPPED LOOSE. THEY MUST BE BOLTED BETWEEN THE DRYER AND FILTER SKID AT INSTALLATION. ALL FASTENERS AND GASKETS ARE SUPPLIED.

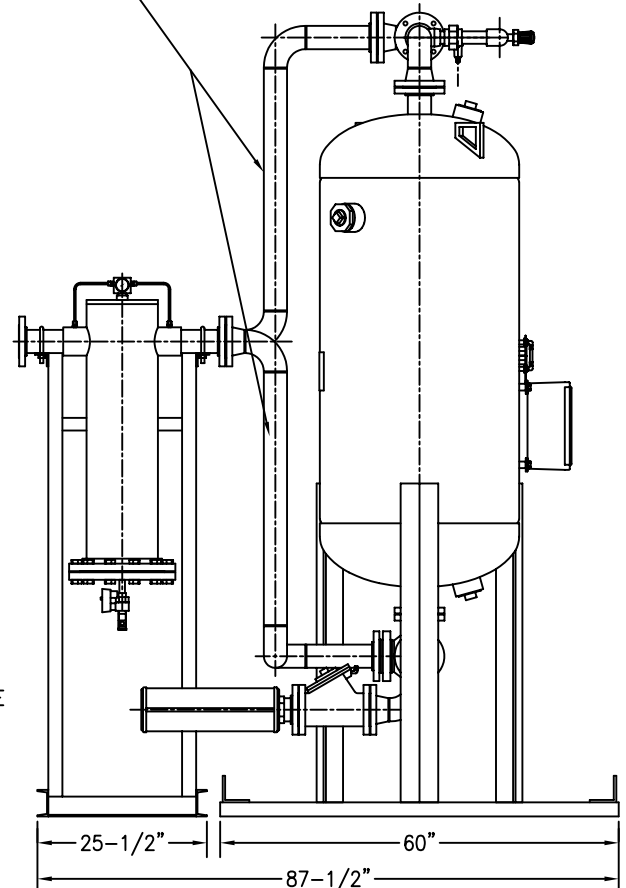
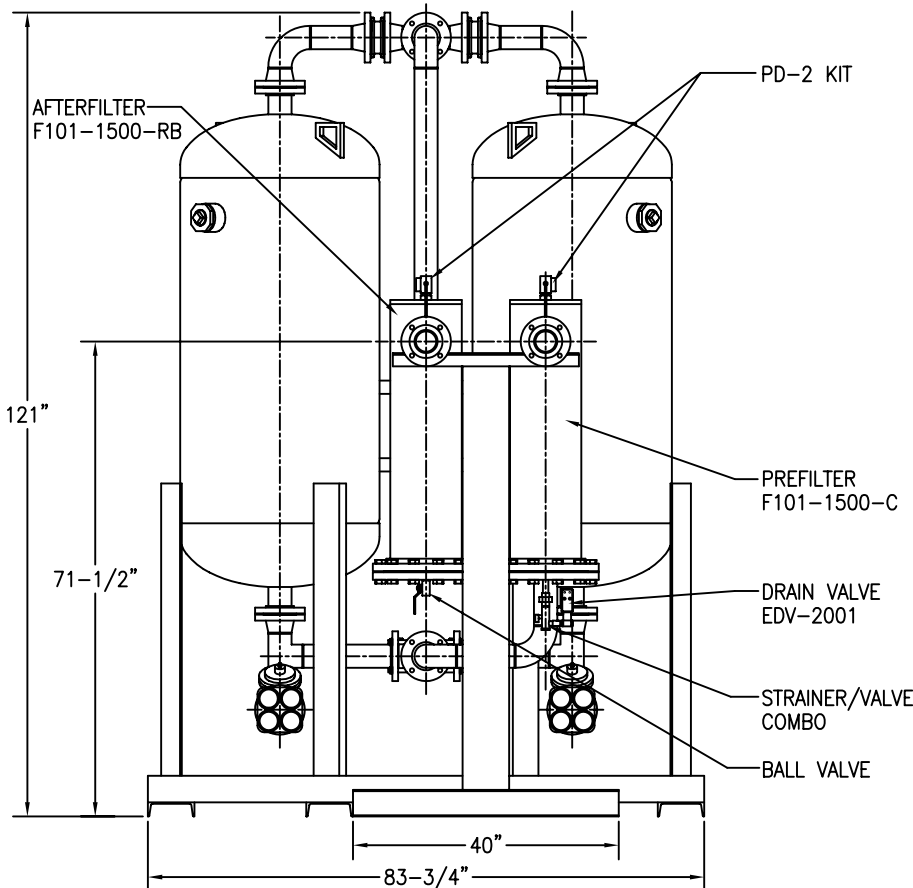

This drawing is the property of
VAN AIR SYSTEMS INC

and is subject to return upon request. It shall not be copied or duplicated in any manner and shall not be submitted to outside parties for examination without the consent of Van Air Systems Inc. It shall be used for reference to work under contract or proposals submitted by Van Air Systems Inc. only.

HEATLESS REGENERATIVE DRYER HL-1500 WITH MOUNTED FILTERS

DRWN BY: JMK	DATE: 05-18-95	DRWG No. SD-13104	REV B
CHECKED:	SCALE: NONE		

APPL:

VAN AIR SYSTEMS INC

Lake City, PA 16423 (814)774-2631 Fax: 814/774-3482 Telex: 91-4548