

APP'L	DATE	LVL	REVISION
SCF	02-01-96	A	ECN:5454
	04-09-98	B	ECN:NO829

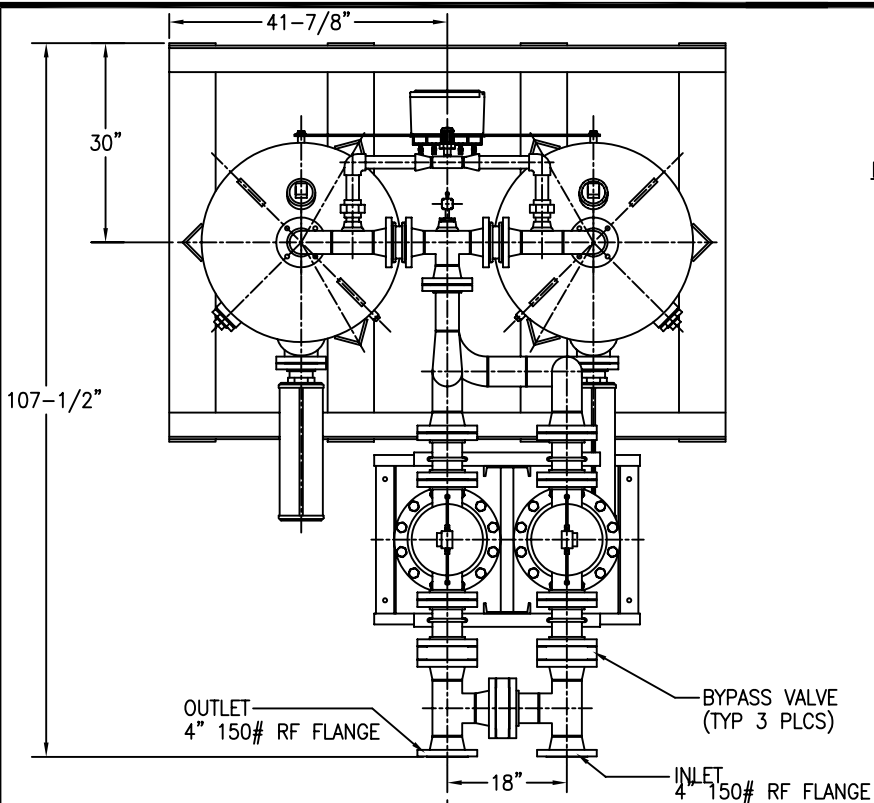

NOTES:

- 1) SYSTEM AMBIENT OPERATING TEMPERATURE RANGE: 40°F TO 120°F.
- 2) SYSTEM OPERATING PRESSURE RANGE: 60 PSIG TO 150 PSIG.
- 3) SYSTEM INLET OPERATING TEMPERATURE RANGE: 40°F TO 120°F.
- 4) SYSTEM RATED FLOW: 1750 SCFM @ 100 PSIG, 100°F.
- 5) APPROXIMATE WEIGHT OF UNIT: 3360 LBS (WITHOUT DESICCANT).
: 5332 LBS (WITH DESICCANT).

INLET AND OUTLET PIPING CONNECTIONS RUNS ARE SHIPPED LOOSE. THEY MUST BE BOLTED BETWEEN THE DRYER AND FILTER SKID AT INSTALLATION. ALL FASTENERS AND GASKETS ARE SUPPLIED.

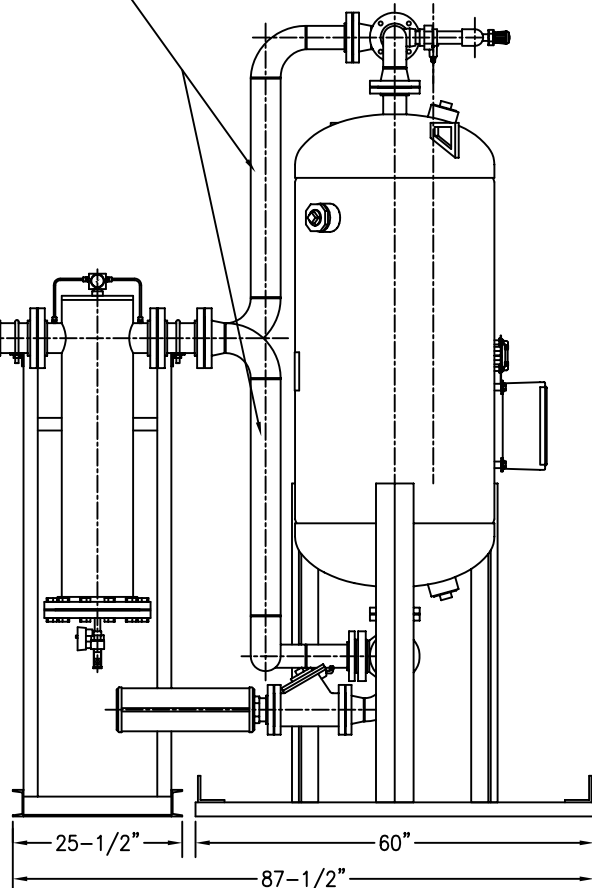
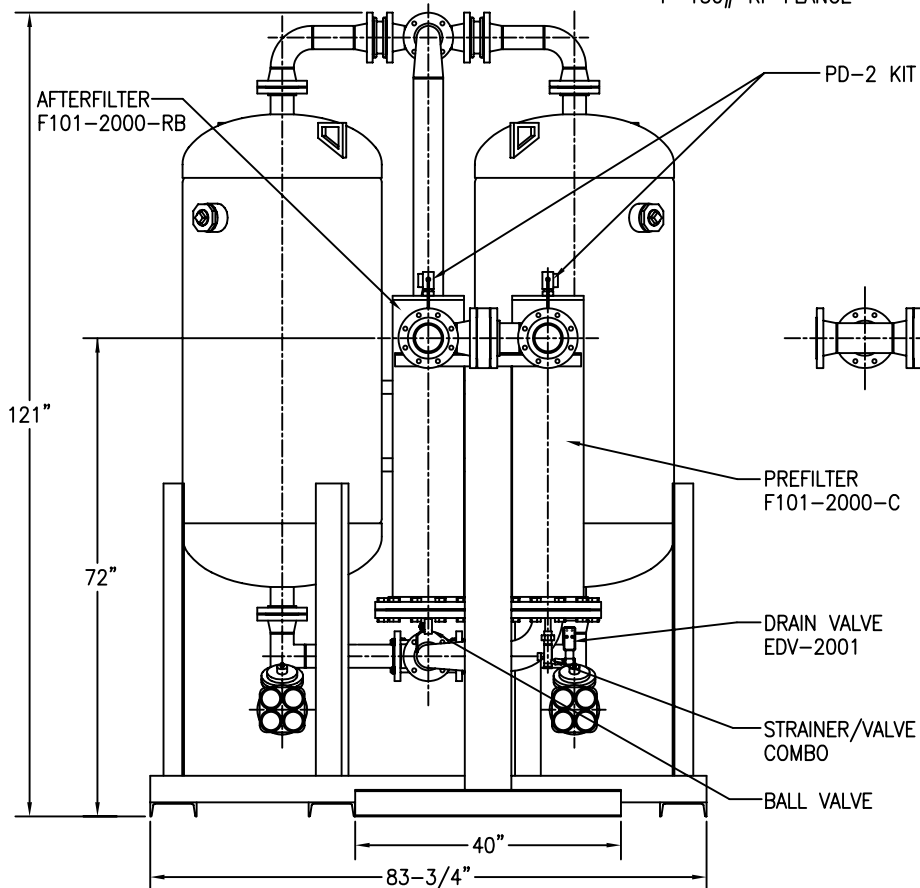

This drawing is the property of

VAN AIR SYSTEMS INC

and is subject to return upon request. It shall not be copied or duplicated in any manner and shall not be submitted to outside parties for examination without the consent of Van Air Systems Inc. It shall be used for reference to work under contract or proposals submitted by Van Air Systems Inc. only.

HEATLESS REGENERATIVE DRYER HL-1750 WITH MOUNTED FILTERS AND 3 VALVE BYPASS

DRWN BY: JMK

DATE: 06-12-95

DRWG No.

SD-13107

REV

CHECKED:

SCALE: NONE

B

APPL:

VAN AIR SYSTEMS INC

Lake City, PA 16423 (814)774-2631 Fax: 814/774-3482 Telex: 91-4548