

APP'L	DATE	LVL	REVISION

NOTES:

- 1) SYSTEM AMBIENT OPERATING TEMPERATURE RANGE: 40°F TO 120°F.
- 2) SYSTEM OPERATING PRESSURE RANGE: 60PSIG TO 150 PSIG.
- 3) SYSTEM INLET OPERATING TEMPERATURE RANGE: 40°F TO 120°F.
- 4) SYSTEM RATED FLOW: 200 SCFM @ 100PSIG, 100°F.
- 5) APPROXIMATE WEIGHT OF UNIT: 550 LBS (WITHOUT DESICCANT).
: 762 LBS (WITH DESICCANT).

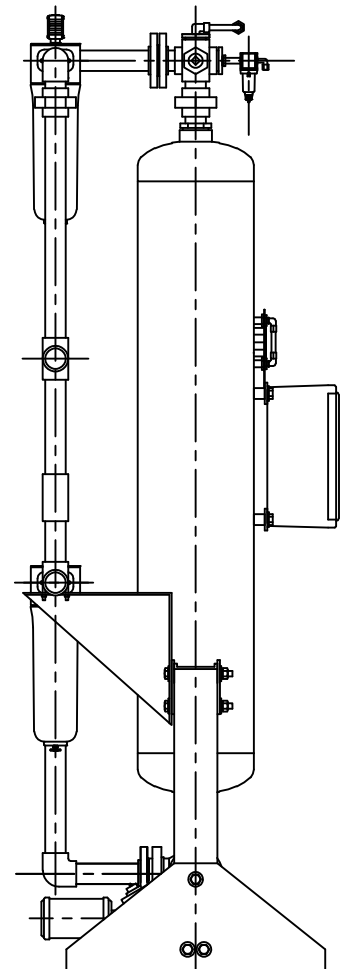
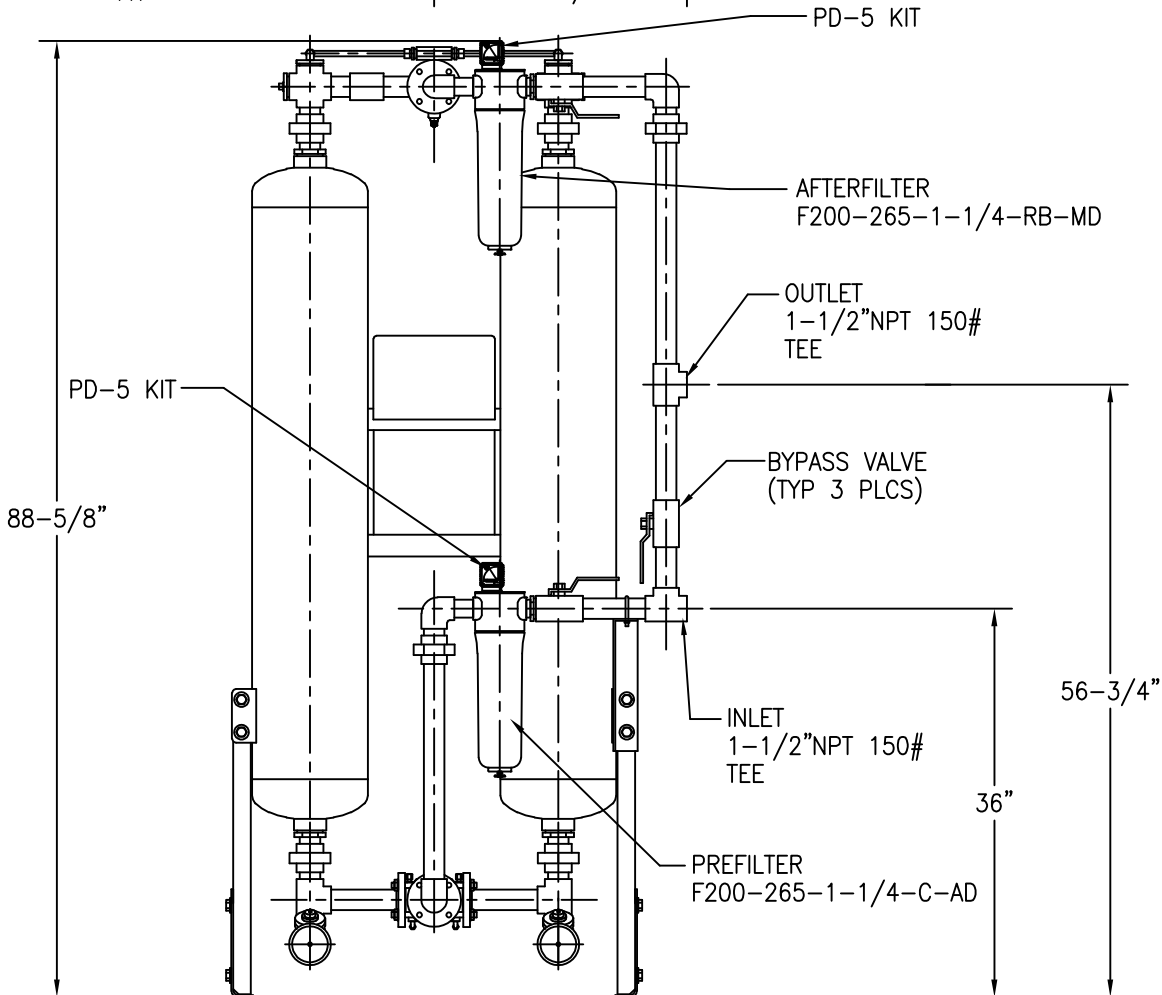
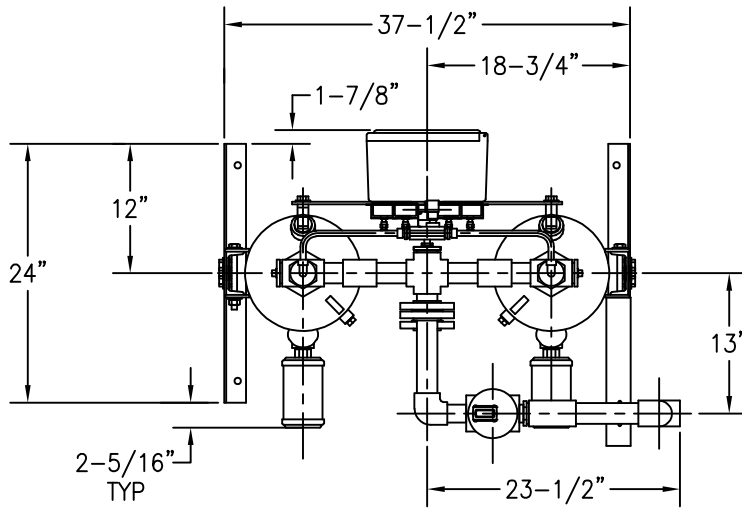

This drawing is the property of **VAN AIR SYSTEMS INC** and is subject to return upon request. It shall not be copied or duplicated in any manner and shall not be submitted to outside parties for examination without the consent of Van Air Systems Inc. It shall be used for reference to work under contract or proposals submitted by Van Air Systems Inc. only.

HEATLESS REGENERATIVE DRYER HL-200 WITH MOUNTED FILTERS AND 3 VALVE BYPASS

DRWN BY: TEK	DATE: 04-08-98	DRWG No.	REV
CHECKED:	SCALE: NONE	SD-13573	

APPL: **VAN AIR SYSTEMS INC**
Lake City, PA 16423 (814)774-2631 Fax: 814/774-3482 Telex: 91-4548