

INSTALLATION, OPERATION & MAINTENANCE MANUAL
FOR
**HEATLESS REGENERATIVE
NATURAL GAS DRYER SYSTEM**

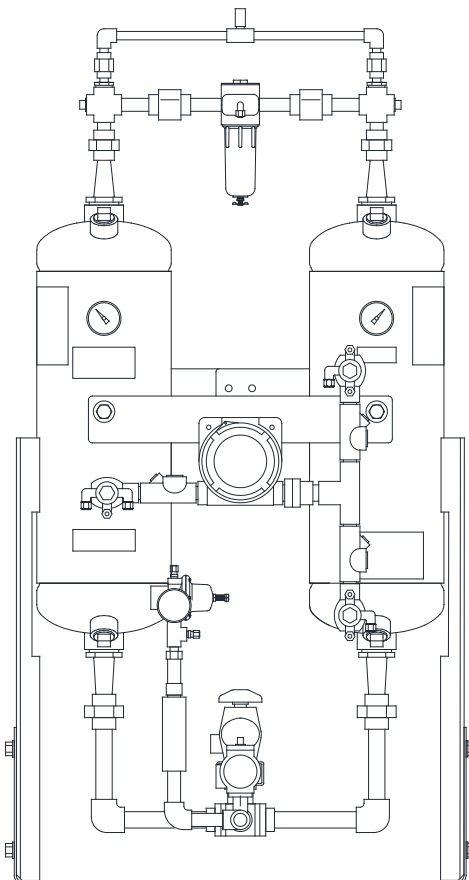

MODEL: HLSXG55 12V DC
PART NO: 81-2526

WARNING

READ ALL INFORMATION IN THIS MANUAL BEFORE BEGINNING INSTALLATION OR OPERATION OF THE DRYER. BEFORE STARTING INSTALLATION AND/OR MAINTENANCE PROCEDURES, TURN OFF THE MAIN POWER TO THE DRYER AND COMPLETELY DEPRESSURIZE THE UNIT TO PREVENT PERSONAL INJURY.

DO NOT REMOVE, REPAIR, OR REPLACE ANY ITEM ON THIS DRYER WHILE IT IS PRESSURIZED.

NEVER OPERATE THIS DRYER ABOVE THE RATED OPERATING CONDITIONS. OPERATION ABOVE SPECIFIED CONDITIONS WILL RESULT IN DECREASED PERFORMANCE, POSSIBLE DAMAGE TO THE UNIT AND/OR PERSONAL INJURY.

1.1 HANDLING INSTRUCTIONS

WARNING

DO NOT LIFT THE DRYER BY THE INLET PIPING OR CONTROL BOX. THESE COMPONENTS ARE NOT DESIGNED TO HOLD THE WEIGHT OF THE DRYER. PERSONAL INJURY AND/OR EQUIPMENT DAMAGE MAY RESULT.

Lift the dryer by the outlet piping (above vessels).

When lifting the dryer, make sure that the chains or cables are clear of all tubing and fragile components.

1.2 STORAGE INSTRUCTIONS

The unit should be stored indoors and covered with a tarpaulin to keep it clean. The location should be free from corrosive gasses and extreme humidity, which will cause damage to the unit.

If outside storage is required, the unit **MUST BE** adequately covered to prevent rain or snow from accumulating on the dryer. The unit must be placed on a paved surface to keep it out of standing water and mud.

1.3 EQUIPMENT CHECK

Inspect the dryer for any damage that may have occurred during shipment. Inspect all fittings, piping connections, fasteners, etc. for loose connections. Also check gauges and lights for cracks or breakage.

IF DRYER HAS BEEN DAMAGED DURING SHIPMENT:

- (1) NOTIFY CARRIER IMMEDIATELY AND FILE A CLAIM.
- (2) CONSULT FACTORY BEFORE OPERATING THE DRYER.

SAFETY INSTRUCTIONS

SECTION 2

2.1 HANDLING

LIFT THE DRYER BY THE OUTLET PIPING (ABOVE THE VESSELS) AS THE OTHER COMPONENTS ARE NOT DESIGNED TO SUPPORT THE WEIGHT OF THE DRYER.

LIFTING BY OTHER COMPONENTS MAY CAUSE PERSONAL INJURY AND/OR EQUIPMENT DAMAGE.

2.2 INSTALLATION

BEFORE STARTING INSTALLATION PROCEDURES, TURN OFF POWER TO THE AREA WHERE THE DRYER WILL BE INSTALLED. SERIOUS PERSONAL INJURY MAY RESULT IF THIS SAFETY RULE IS NOT FOLLOWED.

DO NOT REMOVE, REPAIR, OR REPLACE ANY ITEM ON DRYER WHILE IT IS PRESSURIZED.

THESE ASME CODE VESSELS MUST BE PROTECTED BY PRESSURE RELIEF VALVES. Refer to OSHA 1910.169 Par. b, Sub. Par (3) and ASME Boiler and Pressure Vessel Code, Section VIII, Division 1, UG-125 through UG-136. Also comply with all applicable state and local codes.

WHEN INSTALLING AND OPERATING THIS EQUIPMENT, COMPLY WITH THE NATIONAL ELECTRICAL CODE AND ALL APPLICABLE FEDERAL, STATE, AND LOCAL CODES.

ALWAYS WEAR EYE PROTECTION, GLOVES AND A RESPIRATORY PROTECTIVE DEVICE WHEN HANDLING THE DESICCANT. DESICCANT DUST MAY CAUSE EYE AND SKIN IRRITATION. AVOID BREATHING THE DUST AND PROLONGED CONTACT WITH THE SKIN.

FIRST AID IN CASE OF EYE CONTACT WITH DESICCANT DUST; IMMEDIATELY FLUSH THE EYES WITH PLENTY OF WATER FOR AT LEAST 15 MINUTES. CONSULT A PHYSICIAN.

IT IS CUSTOMER'S RESPONSIBILITY TO FILL ALL CONDUIT SEAL FITTINGS (INCLUDING THE ONES TO THE SOLENIOD VALVES) WITH CHICO COMPOUND AND CHICO FIBER TO ENSURE THE INTEGRITY OF THE EXPLOSION PROOF RATING.

2.3 OPERATION

DO NOT OPERATE DRYER IF EITHER OF THE VESSELS IS LEAKING. IMMEDIATELY TAKE THE DRYER OUT OF SERVICE.

DO NOT OPERATE THIS DRYER ABOVE THE MAXIMUM RATED WORKING PRESSURE.

NOTE

OPERATING CONDITIONS FOR PROPER PERFORMANCE OF THIS DRYER ARE DIFFERENT FROM MAXIMUM OPERATING CONDITIONS FOR THE VESSELS. BE SURE TO CHECK THE DRYER OPERATING CONDITIONS. SEE SECTION 3.1

USE THIS DRYER FOR NATURAL GAS ONLY.

DO NOT OPERATE THIS DRYER IF EITHER VESSEL HAS BEEN DAMAGED BY FIRE. TAKE OUT OF SERVICE IMMEDIATELY AND NOTIFY YOUR CERTIFYING AUTHORITY.

2.4 MAINTENANCE

DO NOT REMOVE, REPAIR, OR REPLACE ANY ITEM ON THE DRYER WHILE IT IS PRESSURIZED. TURN OFF MAIN POWER TO THE DRYER AND DEPRESSURIZE THE DRYER COMPLETELY BEFORE STARTING MAINTENANCE PROCEDURES.

DO NOT WELD OR GRIND THE VESSELS. THEY WILL NOT BE SAFE TO OPERATE. (Note: Any uncertified alteration to the vessels **VOIDS** the ASME Code Certification.)

INSPECT OUTSIDE AND INSIDE OF VESSELS REGULARLY FOR CORROSION AND DAMAGE (I.E. DENTS, GOUGES OR BULGES). ANY DAMAGE TO THE VESSELS CAN MAKE THEM UNSAFE TO USE. IF DAMAGED, TAKE OUT OF SERVICE IMMEDIATELY.

3.1 DRYER SYSTEM SPECIFICATIONS

DIMENSIONS See **SECTION 3.2.**

VESSELS (desiccant towers)

Construction Manufactured to the ASME CODE, Section VIII, Division 1.
 Vessels stamped "UM" symbol.
 Design Pressure 300 PSIG
 Design Temperature -20°F TO 200°F

PIPING

Threaded fittings: ANSI B16.11
 Threaded unions: ANSI B16.11
 Pipe: Carbon steel, Schedule 40

VALVES

Inlet 4-Way ball valve w/ actuator (Qty. 1)
 Outlet Check valves (Qty. 2)
 Purge Ball valve w/ actuator N.C. (Qty. 1)
 Purge Metering Needle valve (Qty. 1)

CONTROL GAS FILTER

Construction Aluminum housing

ELECTRICAL

12V DC, 3.5 Amps

CONTROL BOX

NEMA 4/7 CD
 Explosion Proof (Class 1, Div 1, Groups C & D)

DESICCANT

Material Activated Alumina, 1/8" (2-5 MM) Bead type
 Quantity Per Tower: See **SECTION 3.2.**

OPERATING CONDITIONS

Inlet Operating Pressure MIN 80 PSIG MAX 250 PSIG
 Inlet Operating Temperature MIN 40°F MAX 120°F
 Ambient Operating Temperature MIN 40°F MAX 120°F

RATED INLET CONDITIONS

Inlet Flow 79 MSCFD
 Inlet Gas Pressure 100 PSIG
 Inlet Gas Temperature 100°F
 Relative Humidity (saturation) 100% RH

PROCESS GAS

Natural Gas

MODEL	Flow capacities at various pressures MSCFD							
	80 PSIG	100 PSIG	125 PSIG	150 PSIG	175 PSIG	200 PSIG	225 PSIG	250 PSIG
HLSXG55	<u>65</u>	<u>79</u>	<u>87</u>	<u>95</u>	<u>102</u>	<u>108</u>	<u>114</u>	<u>120</u>

3.2 DIMENSIONS

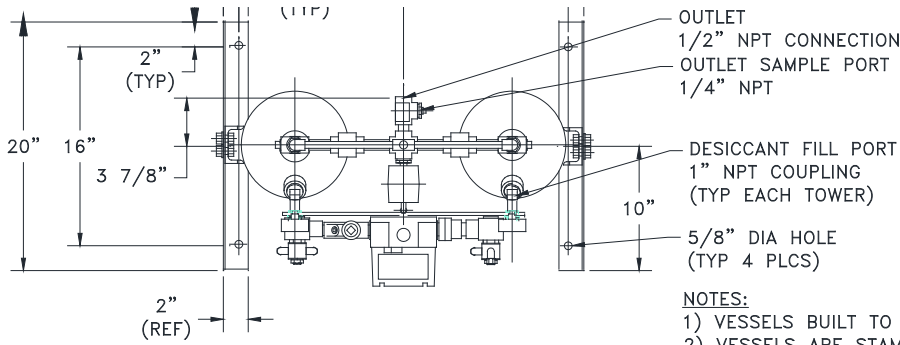

NOTES:

- 1) VESSELS BUILT TO ASME CODE PLUS CURRENT ADDENDA.
- 2) VESSELS ARE STAMPED WITH 'UM' DESIGNATOR.
- 3) DRYER AMBIENT OPERATING TEMP RANGE: 40°F TO 120°F.
- 4) DRYER OPERATING PRESSURE RANGE: 80 TO 250 PSIG.
- 5) DRYER INLET OPERATING TEMP. RANGE: 40°F TO 120°F.
- 6) DRYER RATED FLOW: 55 SCFM (79 MSCFD) @ 100 PSIG, 100°F. (NATURAL GAS)
- 7) AMOUNT OF DESICCANT: 67 LBS (33.5 LBS PER TOWER).
- 8) APPROXIMATE WEIGHT OF UNIT: 220 LBS (W/O DESICCANT)
- 9) ELECTRICAL REQUIREMENTS: 12VDC, 3.5 AMP.
- 10) PIPE FITTINGS ARE FORGED STEEL PER ANSI B16.11.
- 11) CONTROL TUBING IS 316 SS. TUBE FITTINGS ARE STAINLESS STEEL (SWAGELOK).
- 12) EXHAUSTS FROM THE SOLENOID VALVES AND RELIEF VALVE ARE RUN THROUGH A MANIFOLD TO THE PURGE EXHAUST.
- 13) A MOISTURE INDICATOR IS LOCATED IN A TEE IN THE TUBING LINE DOWNSTREAM OF THE CONTROL GAS FILTER.

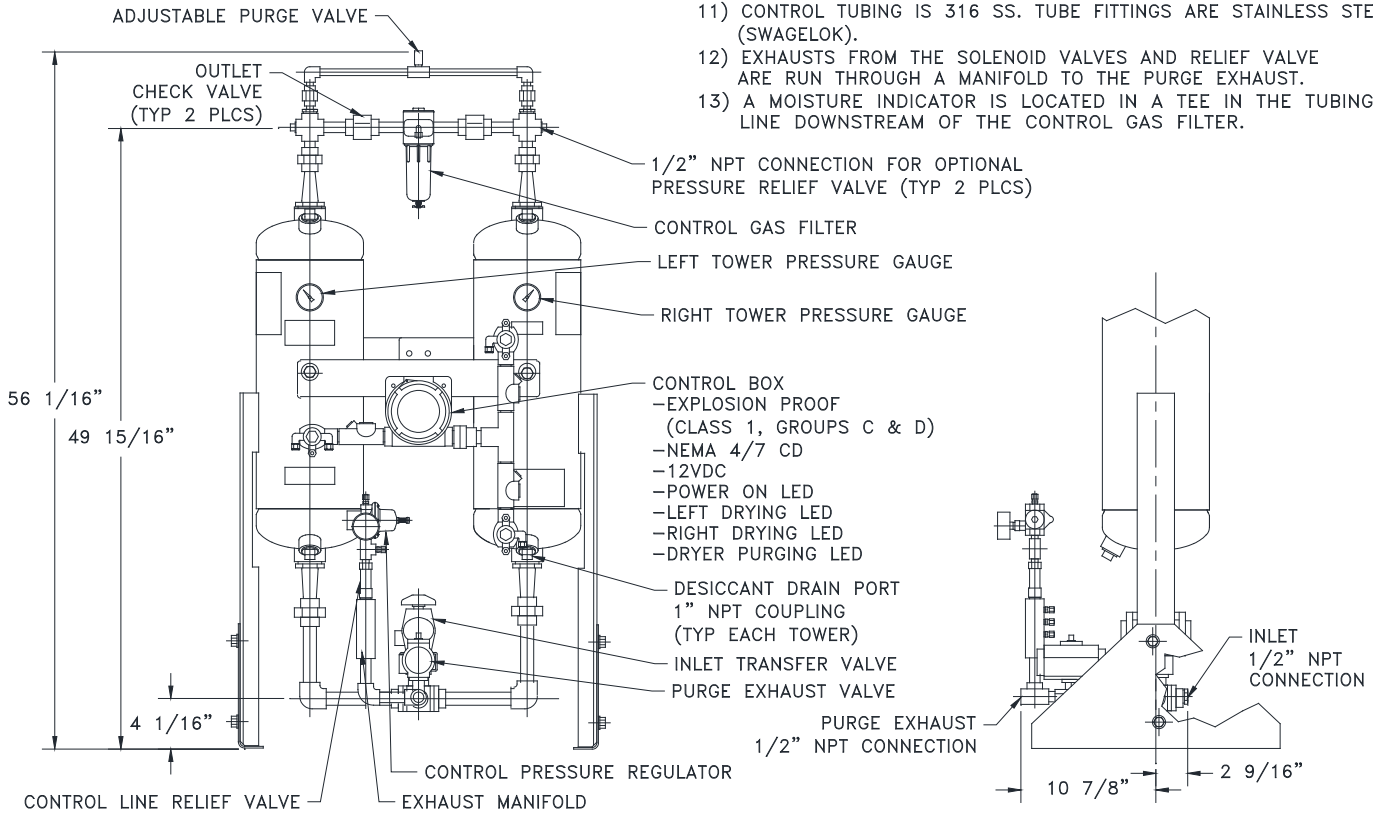

4.1 LOCATION

WARNING

DO NOT INSTALL THIS DRYER IN AN ENVIRONMENT OF CORROSIVE CHEMICALS, POISONOUS GASSES, OR SATURATED STEAM HEAT.

Locate dryer in a protected, well vented area where ambient temperatures are between 40°F and 120°F. Allow sufficient clearance over and around the dryer for access to desiccant fill and drain ports and controls. Refer to SECTION 3.2 for dryer dimensions.

Position the dryer in the upright position on a solid, level, vibration free surface capable of supporting the dryer's weight. Refer to SECTION 3.1 for dryer specifications.

The dryer should not be located in extremely dirty areas where airborne contaminants can accumulate on the dryer. If this cannot be prevented, the dryer should be cleaned periodically.

Once the location has been determined, place the dryer into position. Reference SECTION 1 for handling instructions.

4.2 PIPING AND ANCILLARY EQUIPMENT

CAUTION

Make sure that the inlet gas piping is connected to the LOWER connection of the dryer system and the outlet gas piping is connected to the UPPER connection of the dryer system. Reference SECTION 3.2.

Make sure that the inlet and outlet piping are properly supported. Excessive stress may cause damage and/or dryer malfunction.

Remove protective caps or covers from all piping connections before installing this dryer.

If this dryer is to be installed into an existing piping system, clean the existing inlet piping to remove all accumulated dirt, pipe scale, etc., before connecting the dryer. See FIGURE 4A for Recommended Piping Configuration. Make sure the inlet and outlet shutoff valves are tightly closed before connecting to the existing piping system.

If excessive vibrations are present in the piping, install a flexible hose between the compressor and the dryer inlet.

When installing the piping and any additional components, make sure that adequate pipe supports are used. Excessive stress on the dryer and components may cause damage or premature failure. Use either overhead or stiff-leg type supports.

Make sure that the piping is correctly connected to the dryer. Reference SECTION 3.2 for dryer dimensions and connection locations.

4.3 FILTERS

CAUTION

THE DRYER IS NOT DESIGNED TO HANDLE LIQUID WATER. IF LIQUID WATER IS PRESENT IN THE GAS SYSTEM, A SEPARATOR WITH AN AUTOMATIC DRAIN MUST BE INSTALLED UPSTREAM OF THE DRYER SYSTEM TO PREVENT FLOODING.

Make sure that the elements are installed in all filter housings prior to start up.

A high efficiency coalescing prefilter should be installed before the dryer to remove lubricating oils, dust and pipe scale contamination. A general purpose particulate afterfilter should be installed downstream of the dryer to remove and desiccant dust. It is recommended that the pre and after filters have pressure differential gauges to monitor element life. See FIGURE 4C for recommended pre and after filters.

4.4 PRESSURE RELIEF VALVES

CAUTION

THESE ASME CODE VESSELS MUST BE PROTECTED BY PRESSURE RELIEF VALVES. Refer to OSHA 1910.169 Par. b, Sub. Par (3) and ASME Boiler and Pressure Vessel Code, Section VIII, Division 1, UG-125 through UG-136. Also comply with all state and local codes.

Two connections were provided in the outlet piping of the dryer for the installation of customer supplied pressure relief valves. Reference SECTION 3.2 for location.

4.5 PURGE EXHAUST PIPING

A 1/2" NPT female purge connection is provided on the dryer. Solenoid valve and control line relief valve exhausts also run into this exhaust port. See SECTION 3.2 for location. The customer is responsible to pipe the purge to flair or to re-entrain it to the compressor intake.

IMPORTANT

Make sure that the piping is as short as possible and does not create back pressure on the dryer. To prevent liquid accumulation in the piping and purge valve, the piping must be at the same level or lower than the purge valve.

If the ambient temperature is subject to temperatures below 40°F, freeze protection must be installed.

The distance will determine the size of piping that is recommended. For distances of 10 feet or less, use piping of the same size as the purge valves. For distances up to 20 feet, use piping one size larger than the purge valves.

FIGURE 4A RECOMMENDED PIPING CONFIGURATION AND COMPONENTS

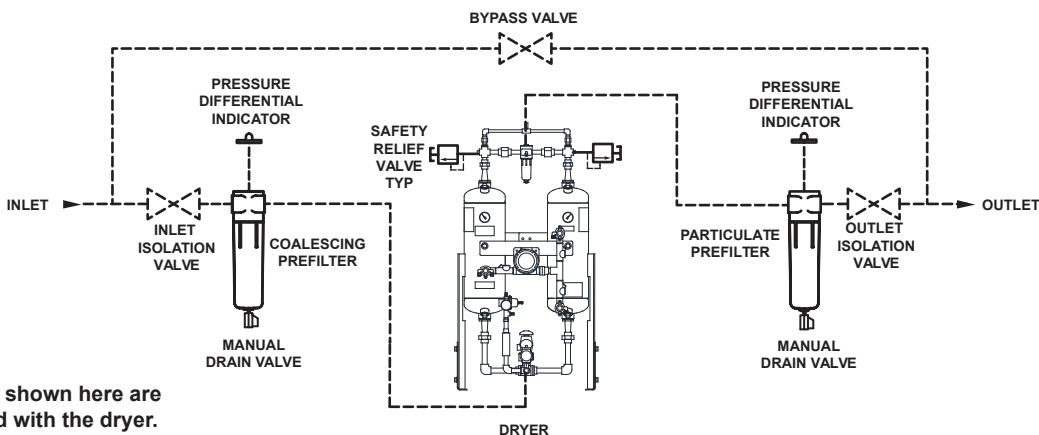

NOTE:
Components shown here are NOT supplied with the dryer.

FIGURE 4B DRYER PNEUMATIC SCHEMATIC

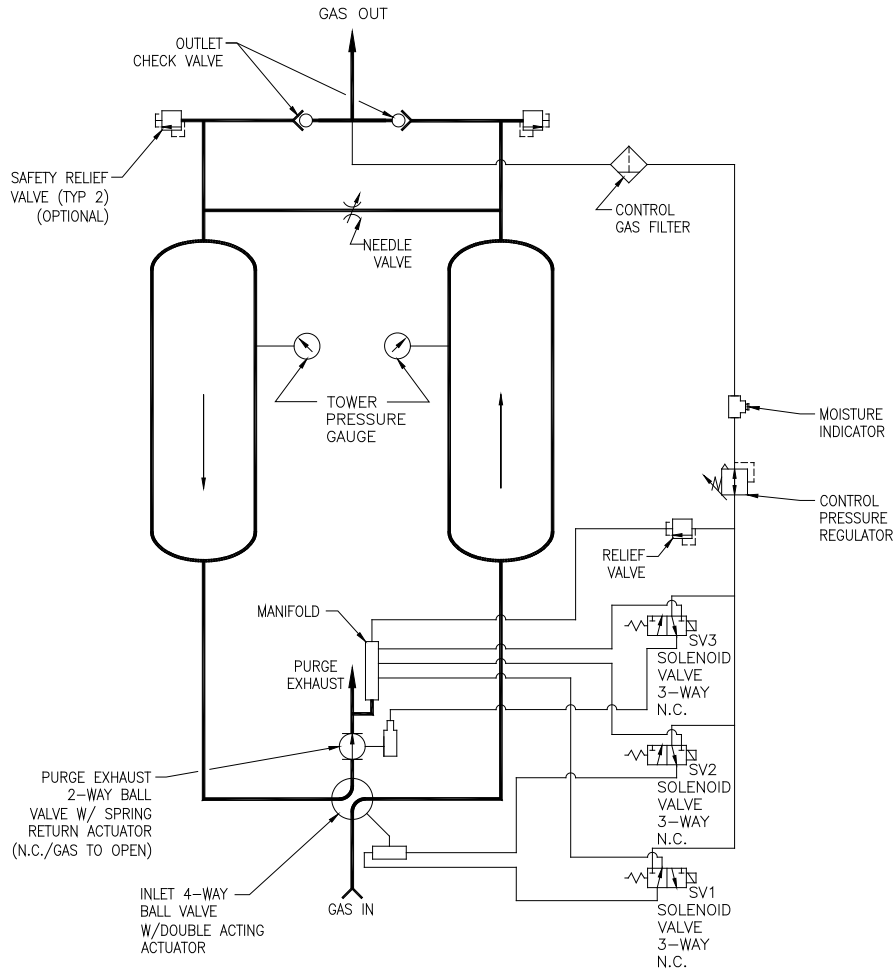

FIGURE 4C RECOMMENDED PRE/AFTER FILTERS

MODEL	PRE-FILTER			AFTER-FILTER		
	MODEL	DRAIN	PD GAUGE	MODEL	DRAIN	PD GAUGE
HLSXG55	GF200-55-1/2-C	MANUAL	PD-6	GF200-55-1/2-RB	MANUAL	PD-6

4.6 ELECTRICAL CONNECTIONS

WARNING

SERIOUS PERSONAL INJURY AND DAMAGE TO THE DRYER WILL OCCUR IF THE DRYER IS CONNECTED TO A POWER SOURCE OTHER THAN THE VOLTAGE LISTED ON THE DATA TAG.

WHEN INSTALLING THE ELECTRICAL CONNECTIONS FOR THIS DRYER, COMPLY WITH NATIONAL ELECTRICAL CODE AND ALL APPLICABLE FEDERAL, STATE AND LOCAL CODES

The electrical controls for the HLSXG dryer are housed in a NEMA 4/7 rated metal enclosure that is explosion proof (Class 1, Div 1, Groups C & D).

The power connection to the control box is made through a conduit connection in the top of the control box. Connect the proper conduit and wiring as required by code. Connect the incoming power to the three wires that protrude from the conduit connection. See ladder type wiring diagram in FIGURE 4D.

WARNING

IT IS CUSTOMER'S RESPONSIBILITY TO FILL ALL CONDUIT SEAL FITTINGS (INCLUDING THE ONES TO THE SOLENIOD VALVES) WITH CHICO COMPOUND AND CHICO FIBER TO ENSURE THE INTEGRITY OF THE EXPLOSION PROOF RATING.

Fill ALL conduit seal fittings with Chico compound and Chico fiber per the manufacturer's instructions.

FIGURE 4D DRYER WIRING DIAGRAM

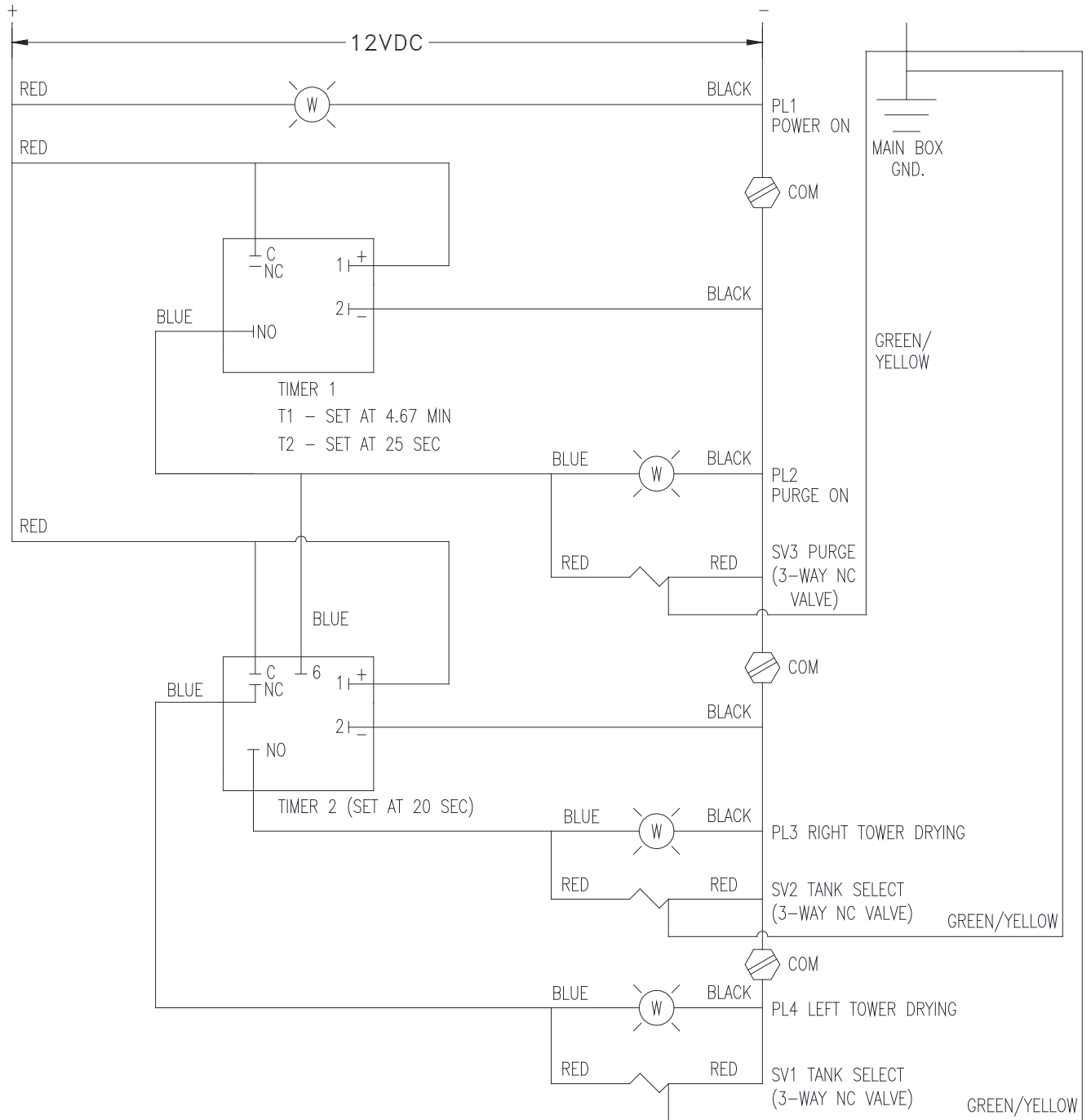

5.1 START UP

WARNING

BEFORE STARTING THIS DRYER, FOLLOW THE INSTALLATION INSTRUCTIONS AND PROCEDURES COMPLETELY. SERIOUS PERSONAL INJURY CAN RESULT IF INSTRUCTIONS ARE NOT CAREFULLY AND COMPLETELY FOLLOWED.

DO NOT REMOVE, REPAIR, OR REPLACE ANY ITEM ON THIS DRYER SYSTEM WHILE IT IS PRESSURIZED.

Close the inlet and outlet isolation valves. Open the bypass valve. (If equipped)

Pressurize the piping system to the dryer. Once the system is pressurized, slowly open the inlet isolation valve. DO NOT open the outlet isolation valve.

Turn ON the power supply to the dryer. One tower will pressurize. The other tower will remain depressurized. The purge valve will open and purge gas should be exhausting from the dryer.

Dryer will begin a 10 minute cycle. The dryer will operate for 5 minutes on each tower.

The dryer is equipped with a purge metering valve. The setting should be checked before placing the dryer on stream. **SEE SECTION 5.2.**

The desiccant bed should be conditioned per **SECTION 5.3** before placing the dryer on-stream.

Place the dryer on-stream by opening the outlet isolation valve and closing the bypass valve (If equipped).

5.2 ADJUSTING THE PURGE FLOW

IMPORTANT

NEVER OPERATE THE DRYER WITH THE PURGE METERING VALVE CLOSED. IF THE VALVE IS CLOSED, THE REGENERATING TOWER WILL NOT REPRESSURIZE.

DO NOT ADJUST THE PURGE METERING VALVE ABOVE OR BELOW THE RECOMMENDED SETTING FOR THE OPERATING CONDITIONS OF THIS INSTALLATION. IMPROPER SETTING MAY CAUSE POOR DRYER PERFORMANCE AND/OR EXCESSIVE USE OF PROCESS GAS.

The purge flow can be adjusted to suit the operating conditions. The micrometer type needle valve is used to set the purge flow as required.

A purge flow of 10 SCFM is required to properly regenerate the desiccant beds.

Before placing the dryer on stream, check the purge metering valve setting. Reference **FIGURE 5A**. The valve is equipped with a set screw, which must be loosened before the valve is adjusted. Adjust the valve to the desired setting. Tighten the set screw to prevent tampering.

5.3 CONDITIONING THE DESICCANT BED

To condition the desiccant bed, the dryer is operated without any outlet flow, while the towers regenerate with purge gas.

Turn on the Power to the dryer.

Observe the dryer for several cycles to make sure that it is operating properly.

At initial start up or after extended shutdowns (over one month), the dryer may take 24 to 48 hours of continuous operation for the bed to be conditioned. Moisture that has accumulated on the desiccant bed should be removed before the dryer is placed on stream.

Once the customer supplied moisture indicator on the dryer indicates no moisture, the desiccant bed is conditioned and ready to be placed on-stream.

5.4 SETTING THE CONTROL PRESSURE REGULATOR

The control pressure regulator is located near the purge exhaust connection and it is used to protect the pneumatic actuators on the purge and inlet transfer valves. This regulator should be set at 100 PSIG.

IMPORTANT

DO NOT OPERATE THIS DRYER WITH THE CONTROL AIR PRESSURE REGULATOR ABOVE 100 PSIG TO PREVENT DAMAGE TO THE PNEUMATIC CONTROLS.

5.5 DRYER TIMING ADJUSTMENT

For operation at pressures other than 100 PSIG, the repressurization time may need to be lengthened to allow for complete repressurization. Consult factory for timing changes.

FIGURE 5A PURGE METERING VALVE SETTING

NOTE:
Settings are based on gas specific gravity of 0.61

MODEL	PURGE	80 PSIG	100 PSIG	125 PSIG	150 PSIG	175 PSIG	200 PSIG	225 PSIG	250 PSIG
HLSXG55	10 SCFM	2.3 turns	2.2 turns	2.0 turns	1.8 turns	1.5 turns	1.3 turns	1.1 turns	0.9 turns

6.1 DRYER CONTROL

The dryer control is housed in a metal NEMA 4/7 explosion proof enclosure (Class 1, Div 1, Groups C & D). See **FIGURE 6A** for control box.

The dryer control has the following features:

- Power ON Light
- Left Tower Drying Light
- Right Tower Drying Light
- Dryer Purging Light

6.2 MOISTURE INDICATOR

The moisture indicator is located in the tubing line from the control air filter. The moisture indicator contains a sight glass window in a fitting with an indicator strip inside. A sample of outlet air is directed through the indicator.

The indicator strip will change colors from **PINK (indicating wet gas)** to **BLUE (indicating dry gas)** as the relative humidity changes in the sample of outlet air.

6.3 OPERATION

The dryer operates in a fixed 10 minute cycle. The dryer changes towers every five minutes. The dryer goes through a normal tower changeover sequence (repressurization, tower changeover, depressurization). **SEE FIGURE 6B** for dryer timing chart.

FIGURE 6A CONTROL BOX

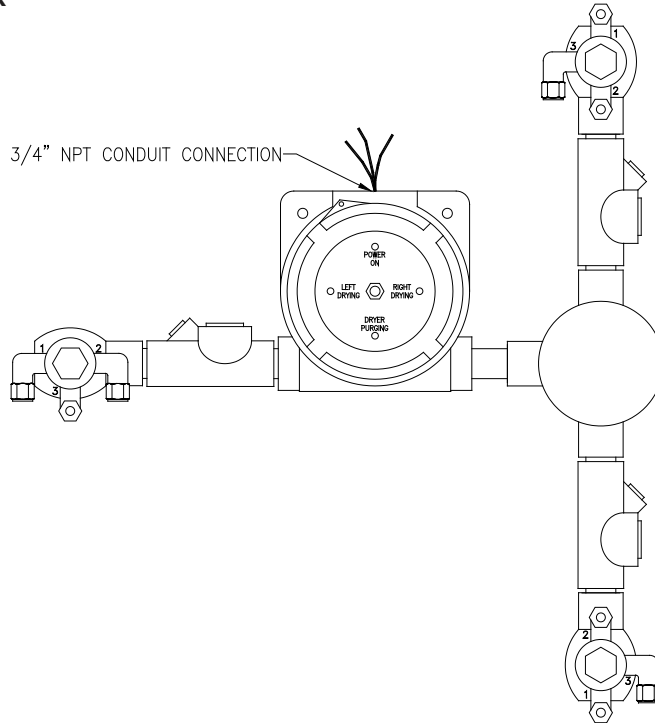

FIGURE 6B DRYER TIMING CHART

NORMAL CYCLE		MINUTES										TIME VALUES	
		0	1	2	3	4	5	6	7	8	9	0	
L E F T T O W E R	DRYING	█	█	█	█	█	█	█	█	█	█	█	5:20 TO 0:20
	REGENERATION		█	█	█	█	█	█	█	█	█	█	0:20 TO 5:00
	REPRESSURIZATION							█	█	█	█	█	5:00 TO 5:20
	CHANGEOVER/DEPRESS.		█	█	█	█	█	█	█	█	█	█	0:20 TO 0:45
R I G H T T O W E R	DRYING		█	█	█	█	█	█	█	█	█	█	0:20 TO 5:20
	REGENERATION							█	█	█	█	█	5:20 TO 0:00
	REPRESSURIZATION							█	█	█	█	█	0:00 TO 0:20
	CHANGEOVER/DEPRESS.		█	█	█	█	█	█	█	█	█	█	5:20 TO 5:45
SV1	3-WAY SOLENOID VALVE	█	█	█	█	█	█	█	█	█	█	0:20 TO 5:20	
SV2	3-WAY SOLENOID VALVE	█	█	█	█	█	█	█	█	█	█	0:20 TO 5:20	
SV3	3-WAY SOLENOID VALVE	█	█	█	█	█	█	█	█	█	█	0:20 TO 5:00 5:20 TO 0:00	
	PURGE EXHAUST VALVE	█	█	█	█	█	█	█	█	█	█	0:20 TO 5:00 5:20 TO 0:00	
	INLET VALVE	█	█	█	█	█	█	█	█	█	█	0:20 TO 5:20 5:20 TO 0:20	

Close the inlet and outlet isolation valves.

Allow the dryer to cycle until it depressurizes completely.

Turn OFF the power to the dryer.

If maintenance is to be performed on the dryer, make sure the dryer is completely depressurized. Tower pressure gauges must read 0 PSIG before removing any item on the dryer.

MAINTENANCE

SECTION 8

8.1 DAILY INSPECTION

The following procedures should be performed daily:

- Check the dryer operating conditions: inlet temperature, ambient temperature, and inlet pressure.
- Monitor the dryer for one complete cycle to make sure it is operating properly.
- Inspect all upstream equipment, aftercoolers, separators, drains and filters.
- Check the pressure differential indicator on all prefilters and afterfilters. If the differential pressure is unacceptable, replace the elements.
- Check the prefilter for proper draining. The prefilter must be drained manually.
- Make sure that all bypass valves are tightly closed.
- Visually check the dryer and piping for damage.
- Visually check the dryer moisture indicator (blue dry or pink wet).

8.2 SCHEDULED MAINTENANCE

12 MONTHS

- Replace the control gas filter element
- Replace the pre-filter and after-filter elements

24-60 MONTHS

- The desiccant in the towers should be replaced every two to five years. The life of the desiccant will vary depending on the inlet gas conditions. Systems with excessive contaminants and/or inadequate filtration will decrease the life span of the desiccant drastically. Once the desiccant is contaminated with lubricants, it must be replaced.

8.3 DESICCANT REPLACEMENT

WARNING

DO NOT ATTEMPT TO REMOVE FILL/DRAIN PLUGS UNTIL ALL GAS PRESSURE IS OUT OF THE VESSEL. CHECK ALL TOWER PRESSURE GAUGES, MAKING SURE THAT THEY ARE AT 0 PSIG AND INCOMING PRESSURE HAS BEEN TURNED OFF.

ALWAYS WEAR EYE PROTECTION AND GLOVES WHEN HANDLING THE DESICCANT. DESICCANT DUST MAY CAUSE EYE AND SKIN IRRITATION. AVOID BREATHING THE DUST AND PROLONGED CONTACT WITH THE SKIN.

FIRST AID IN CASE OF EYE CONTACT, IMMEDIATELY FLUSH EYES WITH PLENTY OF WATER FOR AT LEAST 15 MINUTES. CONSULT A PHYSICIAN.

Take dryer off stream following the **SHUTDOWN PROCEDURES IN SECTION 7**.

Remove the plugs from the desiccant drain and fill ports; drain old desiccant from each tower.

Remove all oil, dirt, or scale from the towers and inlet piping. Do NOT weld, grind or sandblast the vessels as this voids the ASME Certification. The vessels may be steam cleaned internally and externally to remove dirt and oil.

CAUTION

Make sure that the towers are clean to prevent contamination of new desiccant.

Replace plugs securely on desiccant drain ports. Apply pipe thread sealant as necessary.

Make sure that the drain plugs are installed before attempting to fill the towers. Load desiccant through the desiccant fill ports. **REFER TO SECTION 3.2 FOR PROPER DESICCANT AMOUNTS.**

Reinstall the fill port plugs. Apply pipe thread sealant as necessary.

Follow **START UP PROCEDURES IN SECTION 5.1** to start up and place dryer in operation.

8.4 CONTROL GAS FILTER ELEMENT REPLACEMENT

Shutdown the dryer per **SECTION 7**.

Turn manual ball valve on bottom of control gas filter to ensure that the dryer is completely depressurized.

WARNING

DO NOT REMOVE THE FILTER BOWL FROM HEAD UNTIL HOUSING IS COMPLETELY DEPRESSURIZED.

After all pressure is out of the dryer, grasp the filter bowl firmly and push upward while turning it counter-clockwise (as viewed from the bottom) to remove it from the filter head. If preferred strap wrenches can be used to remove bowl. Make sure that the bowl does not drop.

Remove the used element from element adaptor in filter head by pulling down. Discard used element properly.

Remove new element from the shipping package. Check to make sure that the o-ring is properly positioned in endcap and has been lightly greased.

Grasp clean element by bottom endcap and push element onto element adaptor firmly, but do not force beyond normal stop.

Check o-ring in filter head. Replace if worn or damaged.

Clean and lubricate threads on bowl with light grease. This will facilitate removal of bowl at next servicing.

Carefully raise filter bowl over element and screw into head, then tighten. **DO NOT OVERTIGHTEN.**

Close manual drain ball valve.

Following the start up procedures in **SECTION 5.1** for the dryer, place the dryer on stream.

9.1 CONTROL REPLACEMENT PARTS

ITEM	DESCRIPTION	PART NO.	QTY
1	Relay, Time Delay Dual Function	26-7171	1
2	Relay, Time Delay Single Function	26-7172	1
3	Solenoid Valve 3-Way	14-2687	3
4	Face Plate	26-7150	1
5	LED, White	26-7173	4

9.2 DRYER REPLACEMENT PARTS

ITEM	DESCRIPTION	PART NO.	QTY
1	Inlet 4-way Valve	14-2453	1
1a	Valve Seat & Seal Kit	26-7507	1
1b	Actuator Seal & Bearing Kit	26-7506	1
2	Check Valve	14-2471	2
2a	Check Valve Rebuild Kit	26-7527	2
3	Purge Valve (ball valve with actuator)	14-2342	1
4	Purge Metering Valve	14-1124	1
5	Diffuser Basket	26-6464	4
6	Control Gas Filter (includes element)	86-20106	1
6a	Element, Control Gas Filter	26-10405	1
7	Desiccant Fill / Drain Plug	14-0341	4
8	Desiccant	-	-
8a	Activated Alumina, 1/8" dia, 25# pail	33-0237	1
8b	Activated Alumina, 1/8" dia, 50# bag	33-0238	1
9	Pressure Gauge	29-0376	2
10	Control Pressure Regulator	26-7566	1
11	Control Line Relief Valve	14-2679	1
12	Exhaust Manifold	26-7585	1
13	Moisture Indicator	26-7629	1

9.3 HOW TO ORDER PARTS

Contact your local Van Gas representative, or contact the factory.

The following information is necessary to order parts:

- Dryer model
- Dryer serial number
- Dryer part number

This information can be found on the front of this manual, or on the data tag located on the inside of the leg of the dryer system.



The Van Gas Service Department can be reached by calling 888-606-9303 or faxing 814-774-0778 between 8 AM and 5 PM EST Monday through Friday.

10.1 WARRANTY

Per Van Gas Technologies terms and conditions of sale.

SAFETY PRECAUTIONS

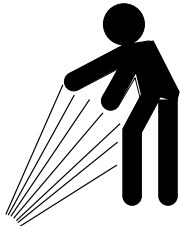
Safety is everybody's business and is based on your use of good common sense. All situations or circumstances cannot always be predicted and covered by established rules. Therefore, use your past experience, watch out for safety hazards and be cautious.

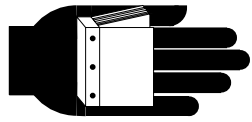
<p>⚠ DANGER</p> 	<p>⚠ WARNING</p> 	<p>⚠ WARNING</p> 
<p>GAS AND OIL UNDER PRESSURE WILL CAUSE SEVERE PERSONAL INJURY OR DEATH. SHUT DOWN COMPRESSOR AND RELIEVE SYSTEM OF ALL PRESSURE BEFORE REMOVING VALVES, CAPS, PLUGS, FITTINGS AND FILTERS.</p>	<p>ELECTRICAL SHOCK FROM IMPROPER GROUNDING CAN CAUSE INJURY OR DEATH. GROUND UNIT AND RELATED EQUIPMENT ACCORDING TO NATIONAL ELECTRICAL CODE AND LOCAL REGULATIONS.</p>	<p>READ THE OPERATOR'S MANUAL BEFORE STARTING OR SERVICING THIS UNIT. FAILURE TO ADHERE TO INSTRUCTIONS CAN RESULT IN SEVERE PERSONAL INJURY OR DEATH. REPLACEMENT MANUALS CAN BE OBTAINED BY CONTACTING THE MANUFACTURER.</p>