

APP'L	DATE	LVL	ECN
SCF	10-14-03	A	436

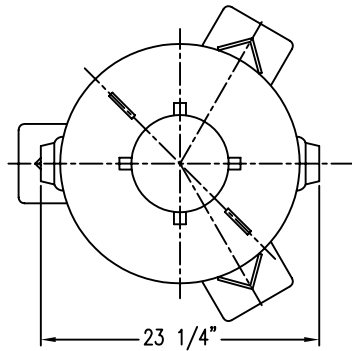

NOTES:

- 1) VESSEL BUILT TO THE ASME CODE PLUS CURRENT ADDENDA.
- 2) VESSEL STAMPED WITH "U" SYMBOL.
- 3) MAXIMUM WORKING PRESSURE: 720 PSIG.
- 4) VESSEL DESIGN TEMPERATURE: -20°F TO 120°F.
- 5) VOLUME: 11.87 CUBIC FEET.
- 6) CAPACITY: 88.8 GALLONS.
- 7) APPROXIMATE WEIGHT: 810 LBS.
- 8) VESSEL EXTERIOR COATING: ALKYD PRIMER WITH WHITE ENAMEL FINISH.

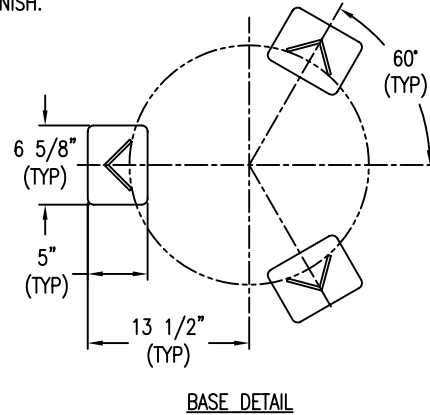
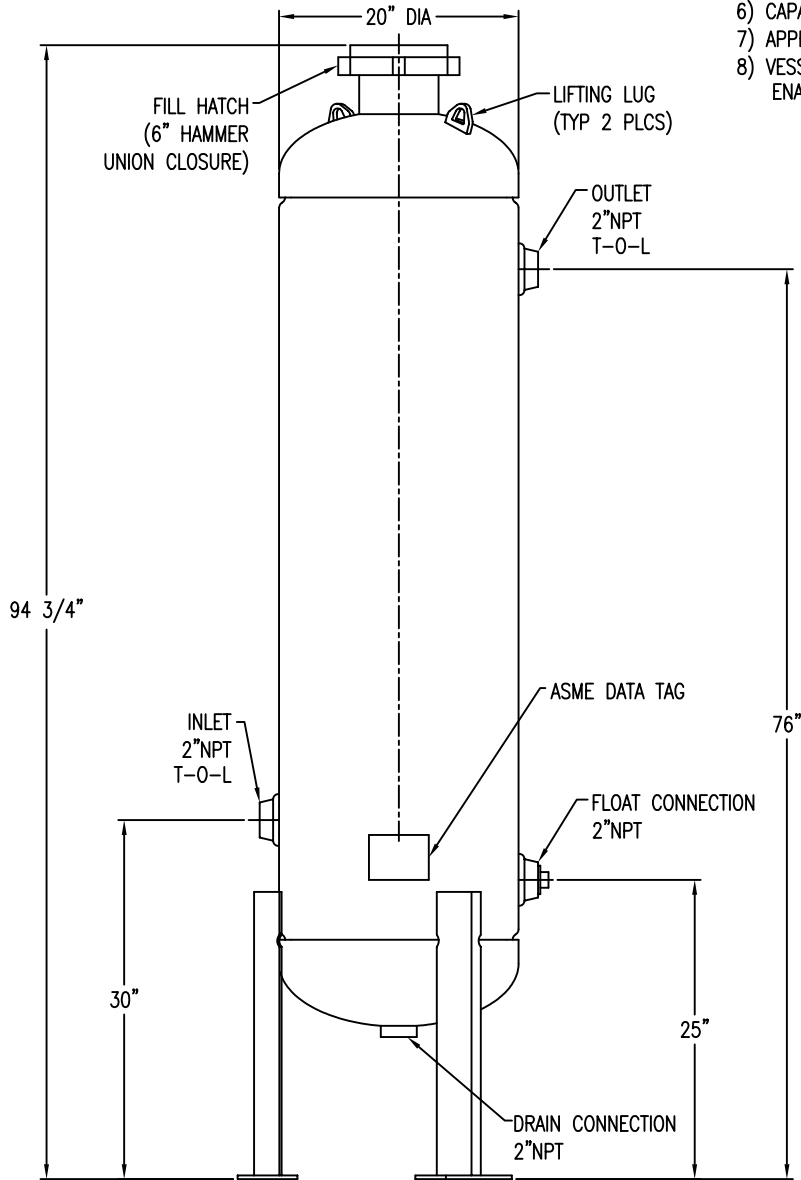

PT #80-1332

THIS DRAWING IS THE PROPERTY OF
VAN AIR INC.

AND IS SUBJECT TO RETURN UPON REQUEST. IT SHALL NOT BE COPIED OR DUPLICATED IN ANY MANNER AND SHALL NOT BE SUBMITTED TO OUTSIDE PARTIES FOR EXAMINATION WITHOUT THE CONSENT OF VAN AIR INC. IT SHALL BE USED FOR REFERENCE TO WORK UNDER CONTRACT OR PROPOSALS SUBMITTED BY VAN AIR INC. ONLY.

**GAS DRYER
PLD20-7.2**

DRWN BY: JMK	DATE: 10-29-01	DRWG No.	REV
CHECKED: SCF	SCALE: NONE	SD-13894	A
APP'L: SCF	VAN GAS TECHNOLOGIES™		