

APP'L	DATE	LVL	ECN

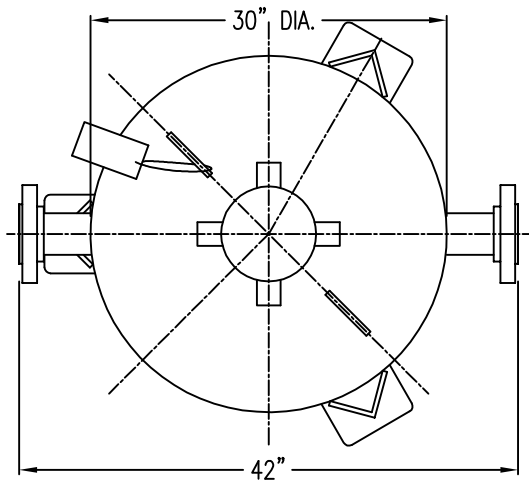

**NOTES:**

- 1) VESSEL BUILT TO THE ASME CODE PLUS CURRENT ADDENDA.
- 2) VESSEL STAMPED WITH "U" SYMBOL.
- 3) MAXIMUM WORKING PRESSURE: 1450 PSIG.
- 4) VESSEL DESIGN TEMPERATURE: -20°F TO 120°F.
- 5) VOLUME: 26.18 CUBIC FEET.
- 6) CAPACITY: 195.87 GALLONS.
- 7) APPROXIMATE WEIGHT: 3030 LBS.
- 8) VESSEL EXTERIOR COATING: ALKYD PRIMER WITH WHITE ENAMEL FINISH.
- 9) FLANGE BOLT HOLES STRADDLE CENTER LINES.

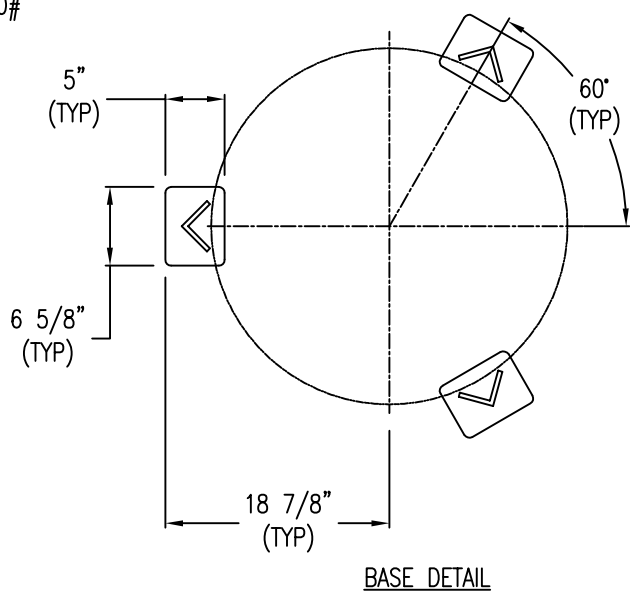
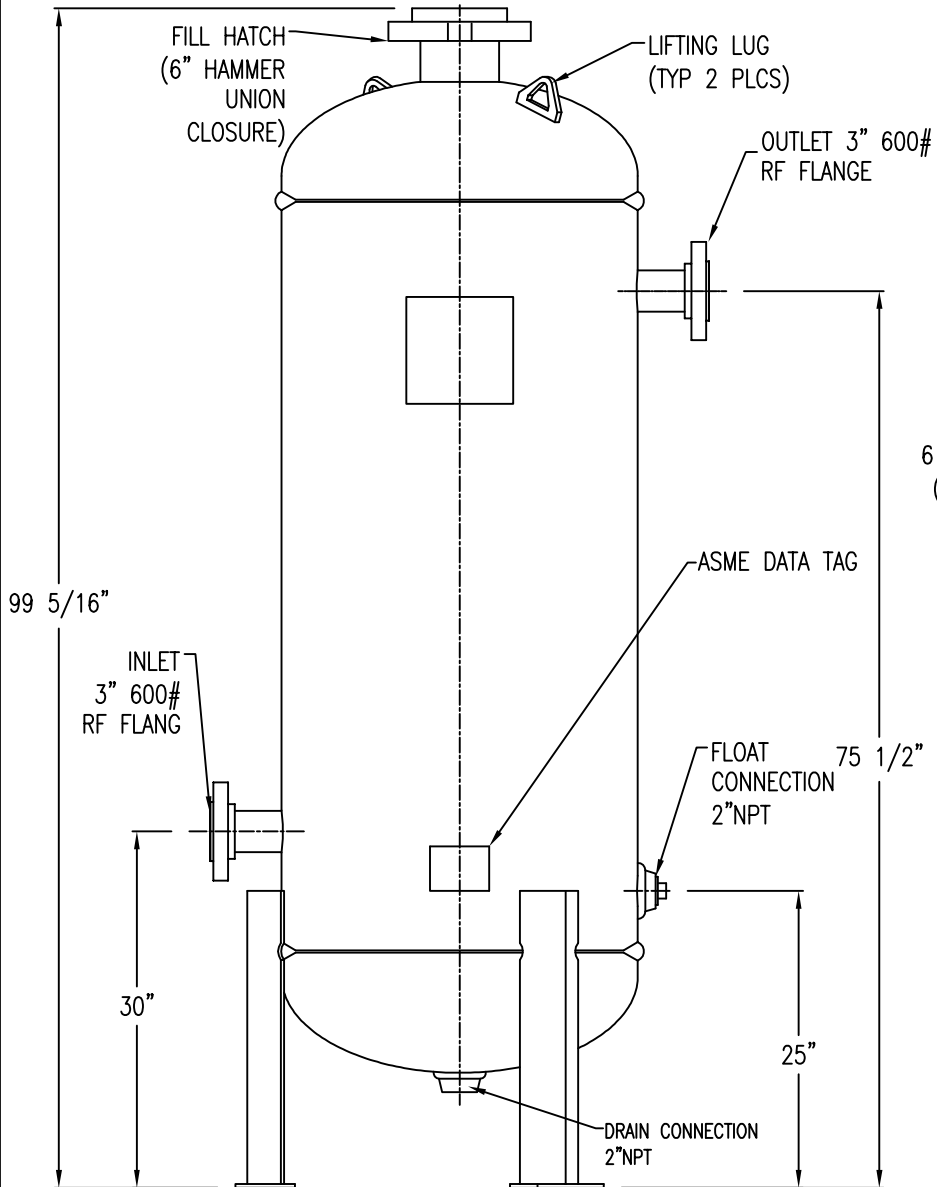

PT# 80-1485

THIS DRAWING IS THE PROPERTY OF  
**VAN AIR INC.**

AND IS SUBJECT TO RETURN UPON REQUEST. IT SHALL NOT BE COPIED OR DUPLICATED IN ANY MANNER AND SHALL NOT BE SUBMITTED TO OUTSIDE PARTIES FOR EXAMINATION WITHOUT THE CONSENT OF VAN AIR INC. IT SHALL BE USED FOR REFERENCE TO WORK UNDER CONTRACT OR PROPOSALS SUBMITTED BY VAN AIR INC. ONLY.

**GAS DRYER  
PLD30-14.5**

DRWN BY: JMY	DATE: 05-11-09	DRWG No.	SD-14433	REV
CHECKED:	SCALE: NONE			

APP'L: **VAN GAS TECHNOLOGIES™**