

APP'L	DATE	LVL	REVISION
	4-19-96	A	ECN:NON696

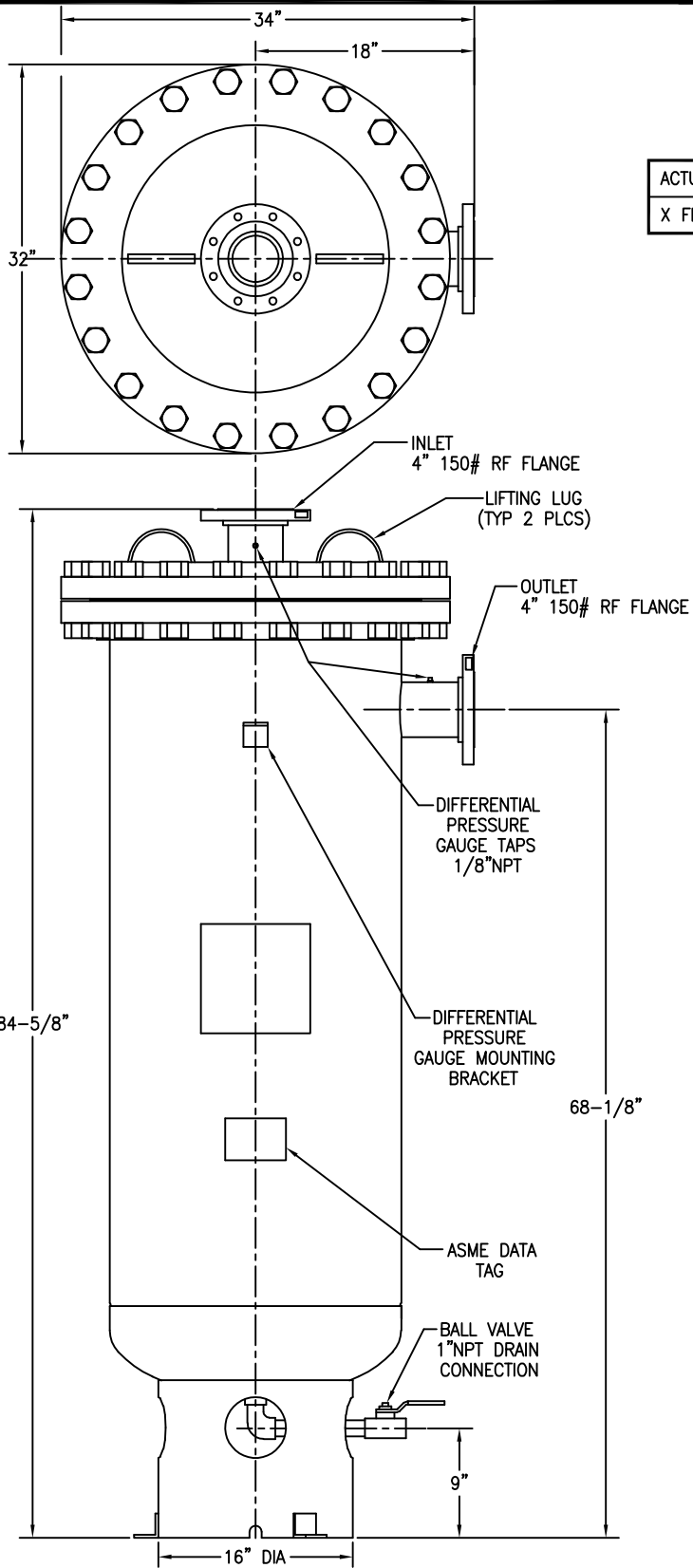

**FLOW MULTIPLIERS (PRESSURE CORRECTION)**

ACTUAL PRESSURE (PSIG)	50	60	70	80	90	100	110	120	130	140	150
X FLOW AT 100 PSIG	.56	.65	.74	.83	.91	1.00	1.09	1.17	1.26	1.35	1.44

**FLOW MULTIPLIERS (TEMPERATURE CORRECTION)**

ACTUAL TEMPERATURE (°F)	50	75	100	125	150	175	200	250	300
FLOW AT 100°F	1.10	1.05	1.00	.96	.92	.88	.85	.79	.74

**NOTES:**

- 1) VESSEL BUILT TO ASME CODE PLUS CURRENT ADDENDA.
- 2) VESSEL STAMPED "U" SYMBOL.
- 3) CORROSION ALLOWANCE: .0625".
- 4) WORKING PRESSURE RANGE: 50-150 PSIG.
- 5) MAXIMUM OPERATING TEMPERATURE: 300°F.
- 6) UNIT APPROXIMATE WEIGHT: 1170 LBS.
- 7) VESSEL CAPACITY: 120.21 GALLONS.
- 8) VESSEL VOLUME: 16.01 CUBIC FEET.
- 9) ALL FLANGE BOLT HOLES STRADDLE CENTERLINES.
- 10) VESSEL EXTERIOR PAINTED WHITE ENAMEL.
- 11) ELEMENT IS SHIPPED IN HOUSING.  
(ELEMENT MODEL #EVME-2500)
- 12) RATED FLOW: 2500 SCFM AT 100PSIG, 100°F (SEE FLOW MULTIPLIERS FOR PRESSURES OTHER THAN 100 PSIG AND TEMPERATURES OTHER THAN 100°F).
- 13) ELEMENT PRESSURE DROP WILL BE LESS THAN 1 PSID AT INITIAL STARTUP. REPLACE ELEMENT WHEN PRESSURE DROP REACHES 3 PSID.
- 14) DO NOT REVERSE FLOW THE ELEMENT.
- 15) ELEMENT EFFICIENCY: 100% FOR PARTICLES OVER 3 MICRON, 99.5% FOR PARTICLES 3 MICRON AND LESS.
- 16) MAXIMUM MIST CARRYOVER: < 1 PPM.  
(ASSUMING AN INLET LOADING OF < 200 PPM)

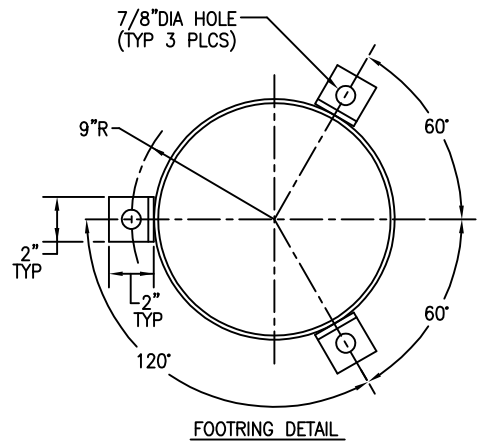

This drawing is the property of  
**VAN AIR SYSTEMS INC**

and is subject to return upon request. It shall not be copied or duplicated in any manner and shall not be submitted to outside parties for examination without the consent of Van Air Systems Inc. It shall be used for reference to work under contract or proposals submitted by Van Air Systems Inc. only.

**MIST ELIMINATOR  
VME2500**

P/N 84-0836

DRWN BY: JMK	DATE: 04-02-96	DRWG No. SD-13243	REV A
CHECKED:	SCALE: NONE		

APPL: **VAN AIR SYSTEMS INC**

Lake City, PA 16423 (814)774-2631 Fax: 814/774-3482 Telex: 91-4548